

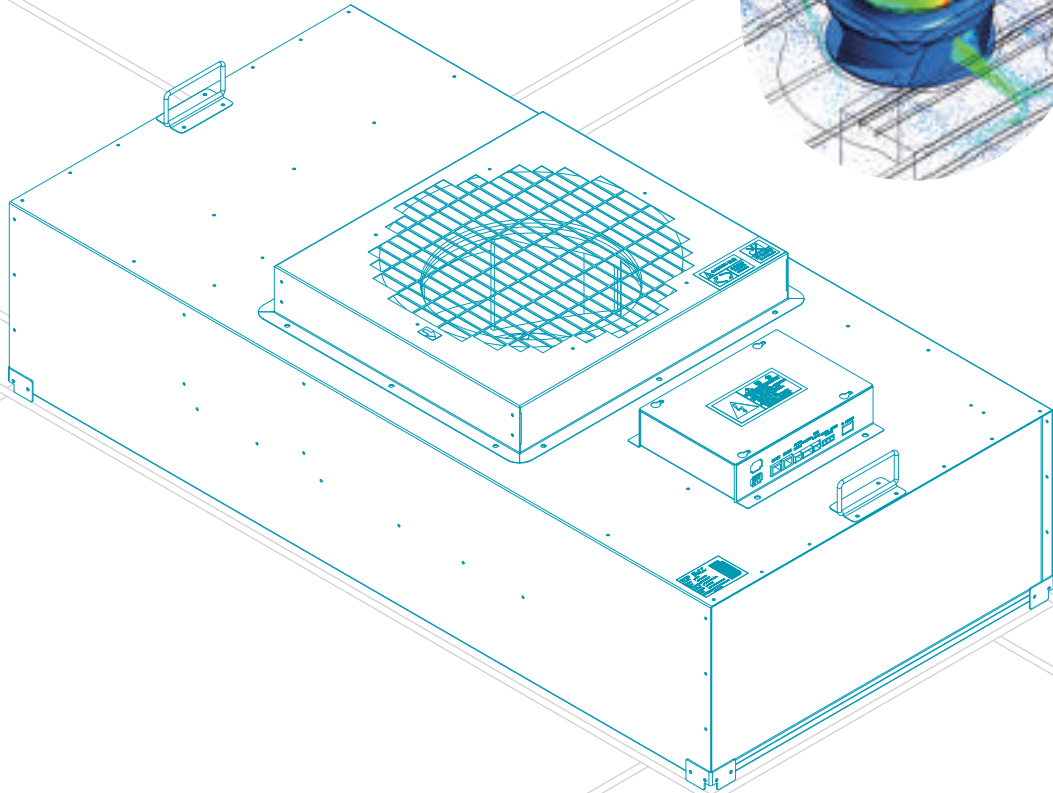

潔淨室 風機濾網機組
CLEAN ROOM FAN FILTER UNIT

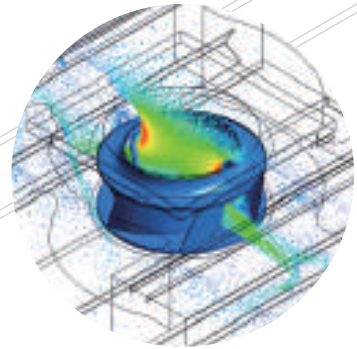

TAIWAN-FFU

Topwell為累積30年的潔淨室工程經驗，結合台灣高科技電子產業技術，及傑出的軟體技術人才，並應用台灣企業優良的加工技術與品質，生產出優於國際品牌的新一代高效率風機濾網機組。讓我們從台灣開始，使全世界都看得到 TAIWAN-FFU。

Topwell, accumulated 30 years of service in cleanroom construction, developed the new generation of high efficiency Fan Filter Unit, in synergy of Taiwan hi-tech electronic technology and HMI software development, manufactured under the reliable quality in Taiwan.



節能省電高效率 FFU 機組，整機效率高達65%

研發與測試 Research and Development

藉由3D氣流模擬軟體，研發最佳氣流場的箱體結構，可降低風道擾流，提升風機效率，促使風量風佈均勻。

FFU casing is designed, via air flow simulation software, to ensure the efficiency and flow distribution.

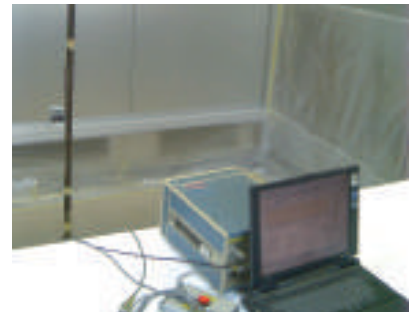
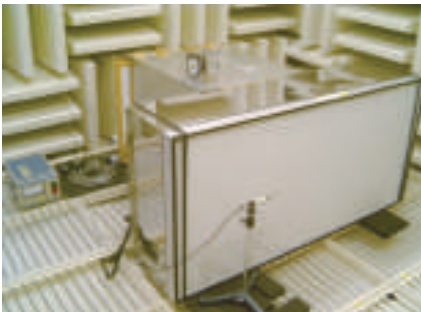
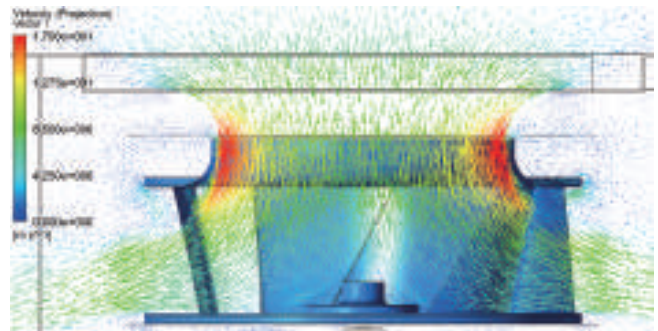

產品經專業研究機構的測試與驗證，確保研發數據的正確性，提升產品的效率及品質。
FFU performance is tested and verified by third party labor research institute.

風扇特性分析 Fan Features

多種不同特性葉輪的組合應用，達成高效率低噪音的使用目標。

Aerofoil or centrifugal fan is selected to meet the application requirement.

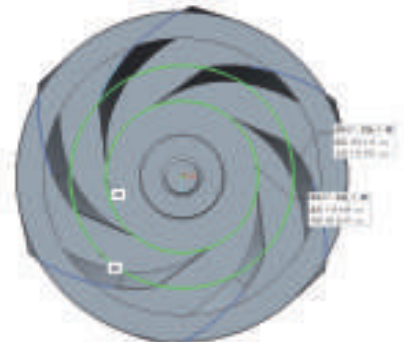
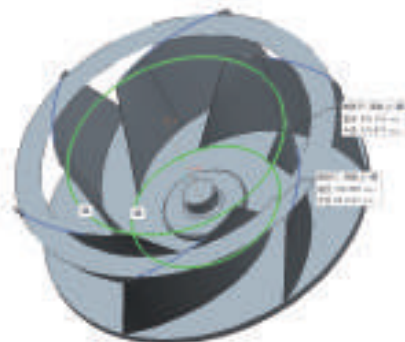

自製DC直流無刷馬達 In-house BLDC Motor Production Line

自製高效率直流無刷馬達，機電效率高達90%以上，軸心與軸承處具抗電蝕 (Current Burn)設計，為確保軸承使用壽命，選用高規材質，針對軸承鋼珠，其設計壽命 $L_{10}>5,000,000$ hrs，而軸承油脂設計壽命 $L_{50}>400,000$ hrs。

The DC brushless motor is designed to achieve over 90% of efficiency, and the shaft/bearing is prevented from electrical pitting to assure the designed bearing life. The design service life is calculated to be $L_{10}>5,000,000$ hrs and $L_{50}>400,000$ hrs for bearing ball and bearing grease, respectively.



3C認證



CE認證

矽鋼片磁路分析 Coil Magnetic Analysis

藉由有限元素分析法，分析、設計矽鋼片磁路。並以田口法優化矽鋼片形狀，縮短研發設計時程，有效利用材料，減少體積，最佳化馬達磁路。

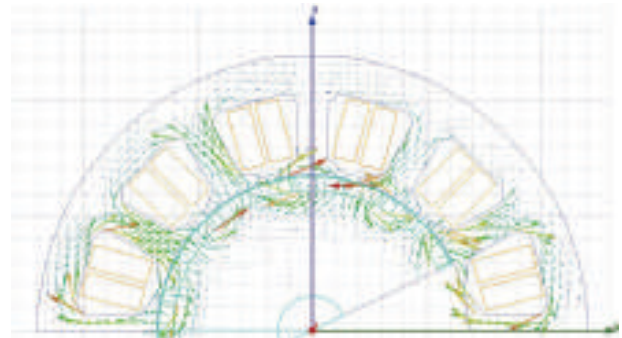
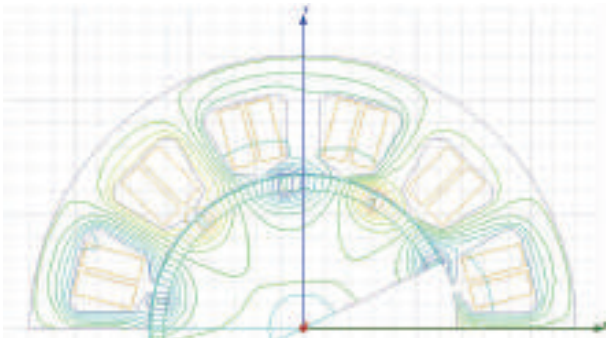

馬達3D模組設計 Motor Enclosure 3D Design

以繪圖軟體繪製馬達各工件3D圖，各工件組裝確認尺寸後發包製作樣品。

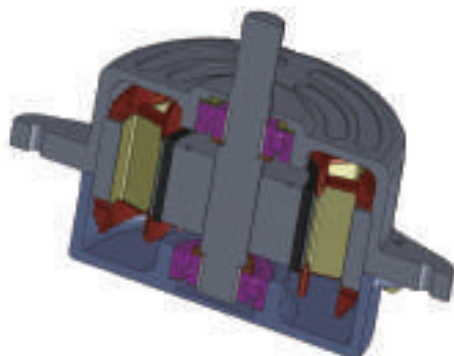

研發設計-電機動力分析 Research & Development-Motor Dynamic Analysis

全電腦控制馬達特性測試系統，採損失分離測法，量測分析出驅動器與馬達效率，同時搭配電力分析儀，同步量測驅動電壓、電流波型、功因及諧波，進而分別調整優化其效率。

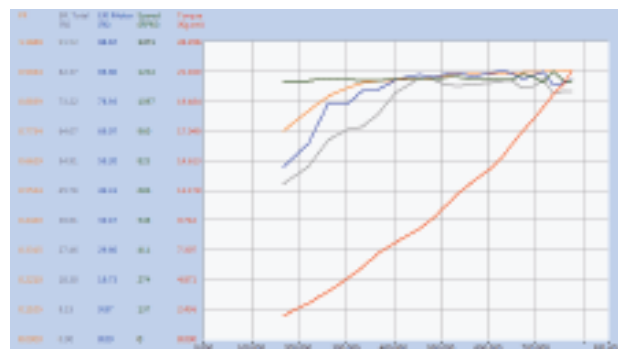

特性驗證測試 Motor Characteristics Testing

透過數位式多功能示波器分析馬達運轉中軸心與接地端電壓波形，可確保培林不會因軸電壓而發生電蝕情形，進而提升培林運轉壽命。

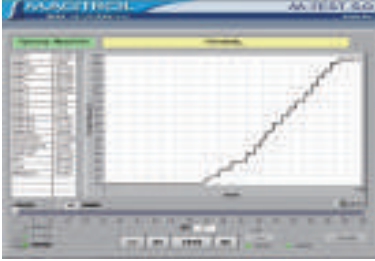

定子品質測試 Stator Quality Testing

採用定子3Q綜合測試機全檢，並於更換漆包線及每日上線時執行首樣檢測，確保定子繞組品質符合規範。

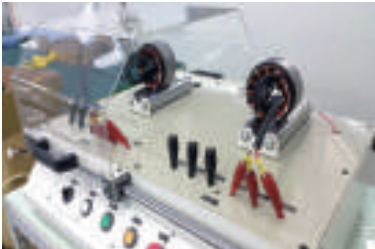

定子繞線 Stator Winding

定子繞線機採用無刷馬達繞線機，其四軸伺服馬達精準地控制繞線位置，穩定的張力控制器確保繞線過程漆包線張力，確保繞製過程中漆包線品質。

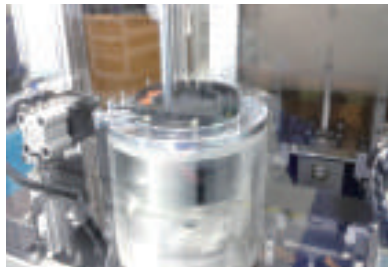

成品快速出廠檢測 Assembly Motor Testing

由我司監控部門與馬達研發協力自行設計製作全自動檢測設備-快速出廠檢測機，依序測試安規、額定負載特性。並以擬似扇作為額定負載，測試馬達額定負載特性，並可輸出報表作統計分析。擬似扇設計更優於磁滯式、磁粉式、渦電流式動力計，無熱衰竭、加載誤差等因素。更接近馬達於FFU實際運作情形。



NO.	DATE	TIME	TESTER	RESULT
1	2023/08/01	10:00	AA	OK
2	2023/08/01	10:05	AA	OK
3	2023/08/01	10:10	AA	OK
4	2023/08/01	10:15	AA	OK
5	2023/08/01	10:20	AA	OK

轉子動平衡製作 Rotor Dynamic Balancing

採用高精度電腦微量平衡機，以ISO 1940動平衡等級G2.5規範執行雙面動平衡校正。

(動平衡製作標準高於ISO 1940 G2.5規範)



真空凡立水含浸 Varnish Vacuum Impregnation Process

採用真空凡立水含浸設備，於200 mmHg真空槽體內進行凡立水含浸，確保線圈內部確實含浸完全，增加線圈品質。



軸電壓可導致馬達軸承的損壞

Electrical corrosion of motor bearing resulted from abnormal of shaft voltage

一般馬達轉動機械在軸與軸承間，及軸承本體內須有油膜的存在，以利軸的旋轉潤滑，而且此油膜對於小的軸電壓具有絕緣作用。當軸電壓大至超過油膜絕緣強度時，電流即從轉軸通過軸承路徑進入外殼導入地位，此時油膜將被破壞，而在軸承及軸的金屬接觸部形成電流通過造成電弧（arc）作用，電弧的高溫即引起金屬的熔融現象。

While motor rotating, the shaft is rotated against the bearing, and the lubricant is presented in form of oil film in between to facilitate the rotation. In addition to the lubrication, this film shall also have the function of insulation against small shaft voltage. If the shaft voltage is too high (or the insulation is too small), high shaft current is generated across the shaft, via bearing, to motor shell and induced to grounding. The generation of high current will create the electrical arc. The high-temperature of arc may cause the melting of metal contact between shaft and bearing.

此熔融現象對於滾動軸承構造，會在軸襯合金處呈現麻點（pitting）狀之孔蝕，或在軸上呈現刮痕狀之損傷，同時電弧作用會導致碳的析出，使潤滑油變黑劣化，受損的金屬表面及碎屑將造成軸承的異常磨耗加劇，終導致整個軸承損壞或是發生高頻噪音。大部份馬達軸承的設計使用壽命為100,000小時，但發生此異常狀後，軸承有可能於1年內就完全損壞。

This melting phenomenon will be presented in form of pitting in the housing of bearing or scratches on the shaft. Due to the electrical corrosion, the lubricant will be blacken and deteriorated from carbon contamination. In combination with the metal injury, it will eventually lead to the generation of noise and bearing damage. Most of the service life of motor bearings is designed of 100,000 hours, but the service life could be drastically reduced to be less than a year due to the electrical corrosion.

軸電流

Shaft Voltage

透過數位式多功能示波器分析馬達運轉中軸心與接地端電壓波形，可確保培林不會因軸電壓而發生電蝕情形，進而提升培林運轉壽命。

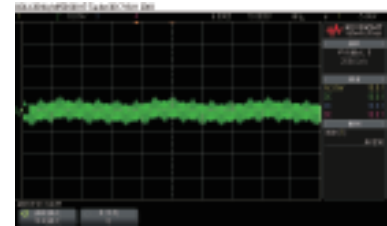
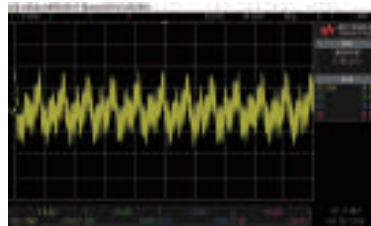

馬達性能測試比較表

Motor performance comparison

備註：一般直流馬達效率約72~82%

Note: General DC motor efficiency is about 72 ~ 82%

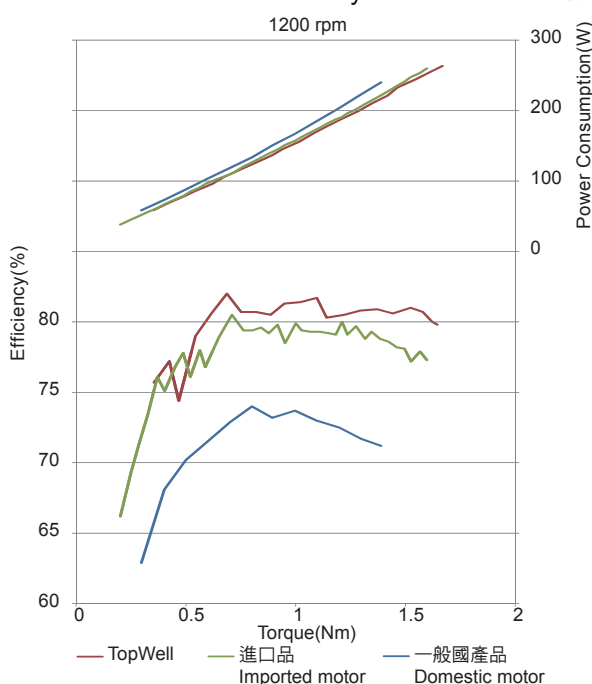

馬達特性分析

Motor Features

TOPWELL

- 鍛造外殼 Precision forged rotor shell
- 旋波驅動 Sine-wave BLDC
- 潔淨室FFU專用 High performance for cleanroom application

OTHER

- 沖模外殼 Stamping rotor shell
- 漏磁 Magnetic loss
- 干擾 Interference
- 低效率 Lower efficiency
- 方波驅動 Square-wave BLDC
- 噪音 Noise
- 震動 Vibration
- 低效率 Lower efficiency
- 挪用商業空調FCU馬達 Clsed for commercial air conditioning FCU
- 電力諧波干擾 Poor requirements of THD & PFC
- 軸電壓抑制 Higher shaft voltage
- 馬達升溫 Motor temperature rise
- 電壓電流保護設計 Inadequate electrical surge protection

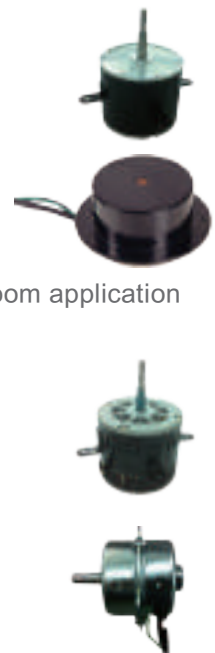

MIT台灣設計製造的高品質高效率控制基板 High efficiency design of FFU controller

控制機板由國際大廠在台灣投資設立的专业製造廠商開發生產，產品符合EMC、SEMI相關規範或標準。控制基板內建諧波抑制器，有效降低用戶端的干擾。

FFU controller is designed by Taiwan professional company, which is invested by international well known company, and is manufactured in Taiwan. The controller is tested to meet the EMC and SEMI standards and the harmonic filter is built-in to minimize the interference of power source.

AC/DC 控制基板 AC/DC motor controller



DC控制基板
BLDC motor controller



AC控制基板
AC motor controller

諧波分析 Harmonic Analysis

透過諧波分析儀測試馬達驅動電壓、電流諧波，修改驅動器端硬體軟體，使其降低馬達運轉中產生之震動及異音，提升馬達壽命。

D50-X 2014A, MY53100117, Mon Oct 29 19:07:26 2018



目前Harmonic數據的要求，大多參照IEEE的規範，電壓380V以上的為15%以下，380V以下為18%以下，topwell全機種的Harmonic值均訂在8%以下的標準。

Refer to IEEE specifications, the harmonic is to be less than 15% and 18% for voltage > 380V and voltage < 380V, respectively. However, Topwell FFU controller is able to achieve the higher standard of harmonic less than 8%.

主要控制功能 Monitoring and control function

- ◆ 單機控制 Individual control
- ◆ 群組迴路控制 Group control
- ◆ 控制中心集體控制 Control Centre by Server
- ◆ 現場直接控制 Local Control by Local Clients
- ◆ 遠端連線控制 Remote Control by Internet
- ◆ 跨平台整合能力 OPC service
- ◆ 工控系統直接整合 HMI ex: Intouch, IFIX



單機運轉資料顯示

Individual control mode

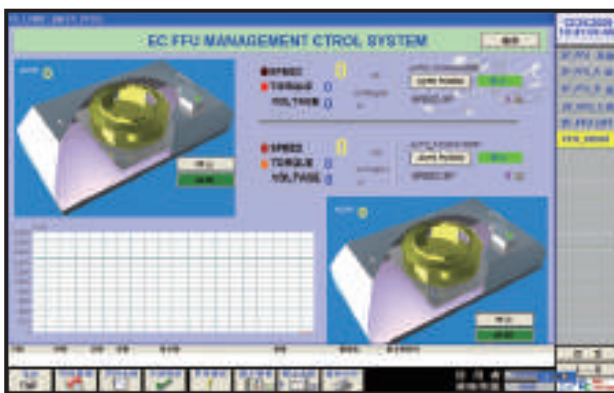

多機群控顯示，點擊圖示單元可顯示單機運轉資料

Group control mode

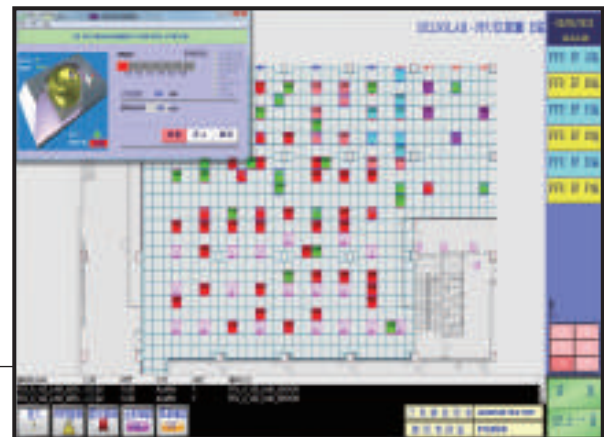

中文INTOUCH 圖控軟體，與廠務監控系統整合容易

INTOUCH software applicable for the monitoring and control system, enable the integration to FMS.



可將CAD圖面直接轉為圖控畫面

Display is easily converted from CAD drawing



圖控系統的軟體編輯及試機調整，Topwell 100% 完全自主處理，可於24小時內完成業主的變更需求。

Testing, commissioning and maintenance service fully local supported.

FFU監控系統架構 FFU System

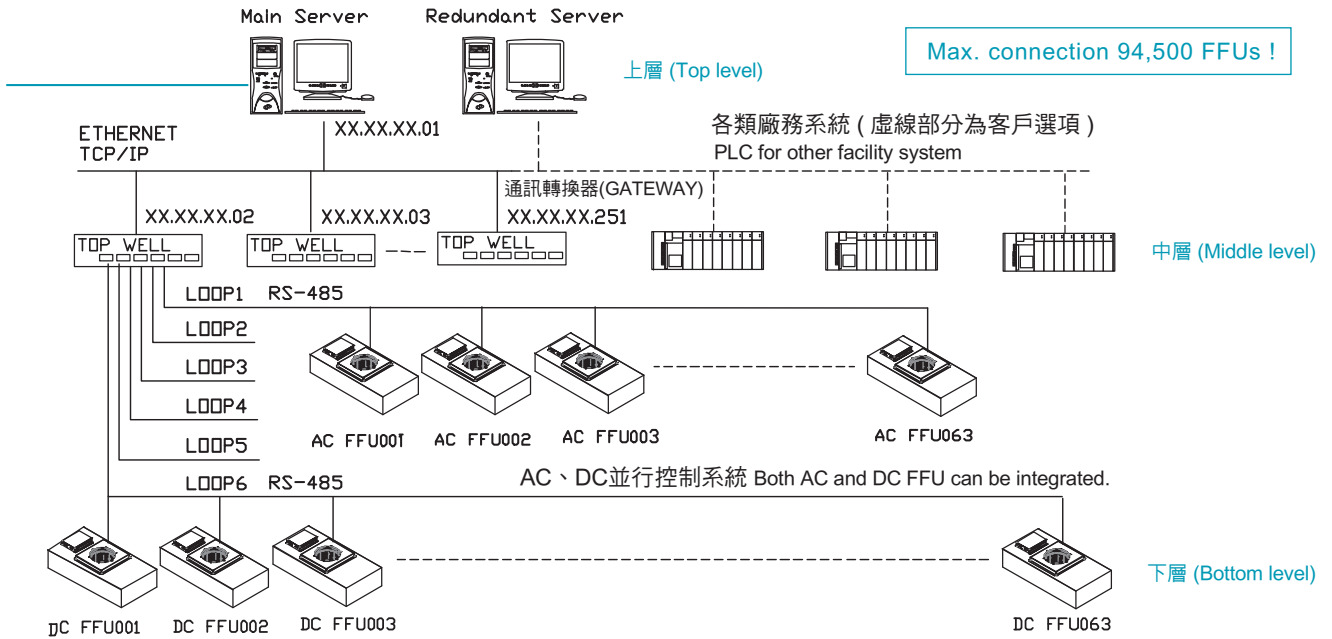

註：本系統之FFU控制器為監控通訊版，另有非監控版控制器提供單機手動調速及警報乾接點功能
 Note: For AC FFU, the non-communication type, which is equipped only with manual control and alarm dry contact, is also available.

上層監控端 Top level: HMI

- ◆ 可透過ETHERNET網路使用套裝圖控軟體，例如：INTOUCH IFIX、CIMPLICITY等市面常用軟體，或自行開發之監控軟體，亦可以整合至既有的廠務系統內。
 Via ETHERNET, the HMI (INTOUCH, IFIX, CIMPLICITY or self-developed software) Monitors and controls FFUs through gateway.
- ◆ 可以透過 RS-232C 對 TOPWELL 之通訊轉換器讀出寫入。
 Direct communication with Topwell gateway by RS-232 is feasible.
- ◆ 可以直接對 FFU 控制器讀出寫入。
 Direct communication with Topwell FFU by RS-485 is feasible.

中層資料收集端 Middle level: Active gateway

- ◆ 資料收集器會主動將下層FFU控制器的資訊收集 Gathering data from FFU controller actively.

特殊規格，適用整合其他監控I/O用途。
 Special request, applicable for other I/O integration.



標準規格，FFU監控系統專用。
 Standard application for FFU system.



下層FFU控制器 Bottom level: FFU controller



LD01 DC FFU控制器 - 網路型
DC FFU controller (M/C)



WD01 DC FFU控制器 - 網路型
DC FFU controller (M/C)
w/ on-board display



LA01 AC FFU控制器 - 網路型
AC FFU controller (M/C)



LA02 AC FFU控制器 - 非網路型
AC FFU controller (non-M/C)

FFU 靜壓值與潔淨室系統壓損的運作關係

FFU static pressure selection in consideration CR system requirement.

錯誤觀念：

一般FFU製造工廠僅將FFU裝上HEPA後，即於開放空間測量風量及耗電數據，實際上此時FFU的壓損僅約100~150Pa(僅HEPA的阻抗)，遠低於潔淨室實際的壓損阻抗值170~220Pa (詳圖)，故測量的風量及耗電數據雖可達到規範數值，但實際裝置在潔淨室後，將因高架地板、冷卻盤管、風道、管線等阻抗的增加，使得FFU的性能降低而無法滿足潔淨室的要求條件。

Misleading information:

The FFU static pressure selection shall consider the CR system static pressure loss including raised floor, cooling coil, grille, shaft space, piping/ducting space and additional pressure for future filter dust accumulation, which is ranged from 170Pa to 220Pa (see drawing below). However, most of FFU design from other manufacturers only considers the filter pressure loss(100-150Pa), which is far less than actual CR requirement and results in insufficient air flow.

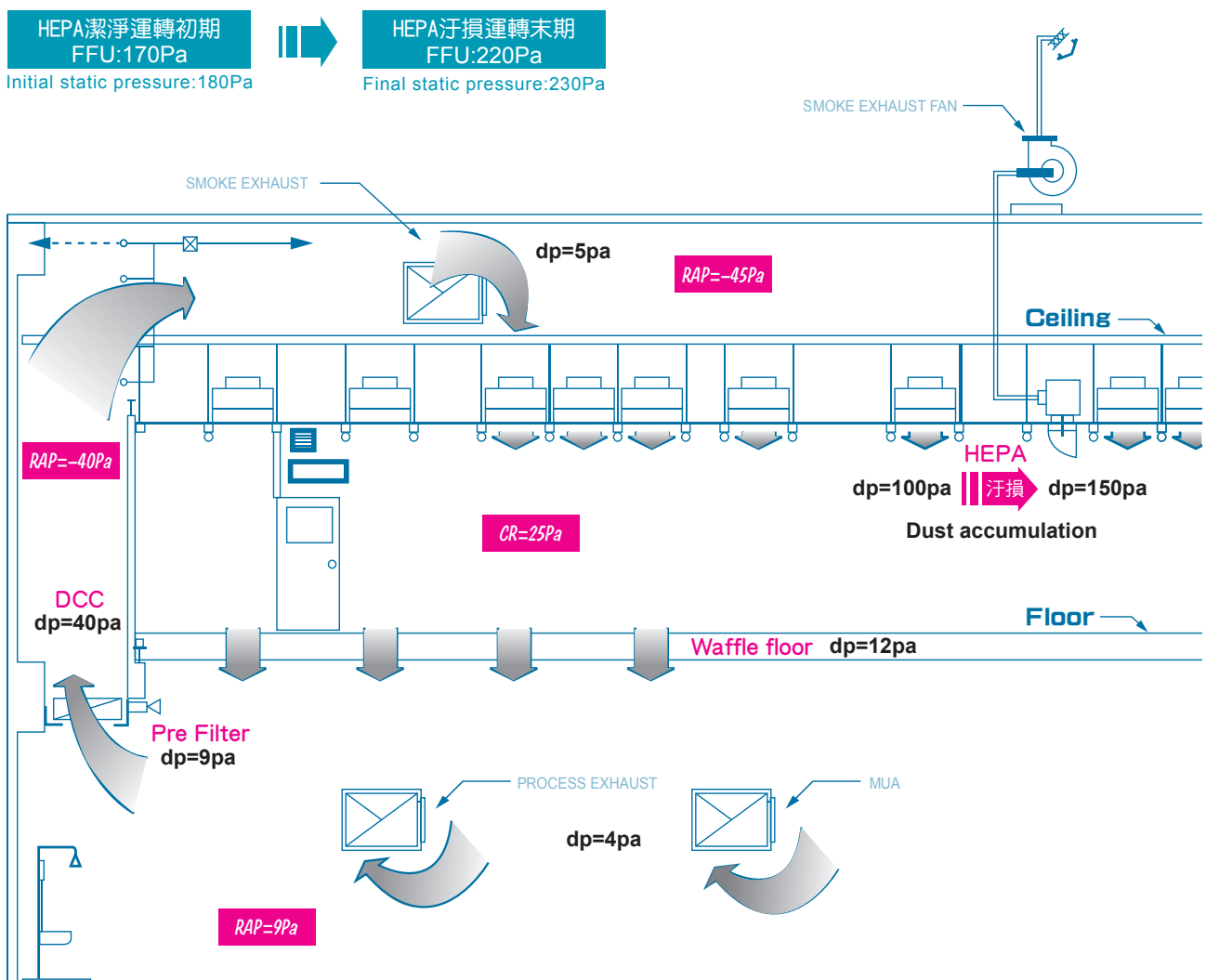

FFU網路及CR環境監測整合系統 ENVIRONMENTAL MONITORING INTEGRATION SYSTEM

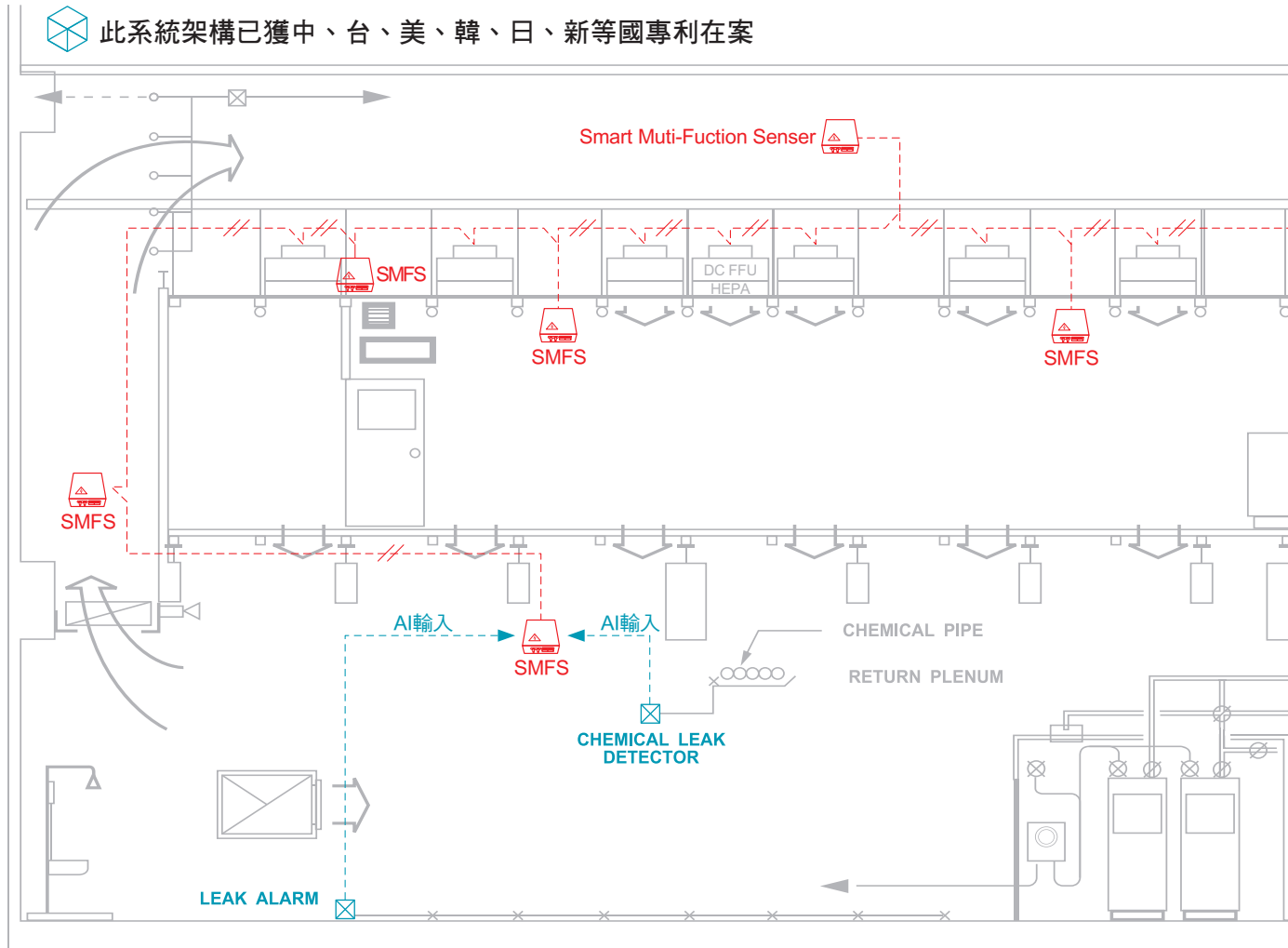

智能網路監控系統功能 Intelligent network monitoring system function

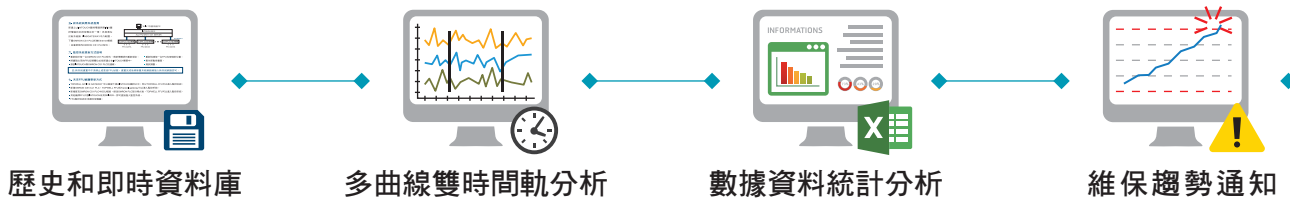

SMFS 模組監控功能 SMFS Module monitoring function

- ◆ 壓差、壓力、溫濕度、表面溫度、風速、水溫、塵埃、VOC、流量、振動、電力等。
- ◆ SMFS感測器模組可外接AI輸入訊號。



Smart Multi-Function Sensor
【 SMFS 】

CR環境監測/製程條件監測/自動維保趨勢通知/大數據分析

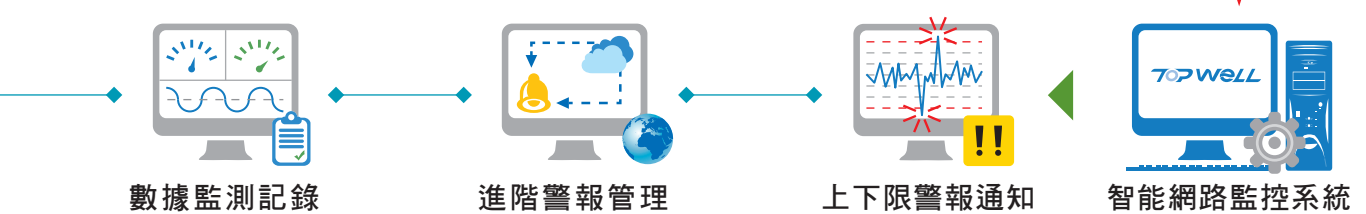
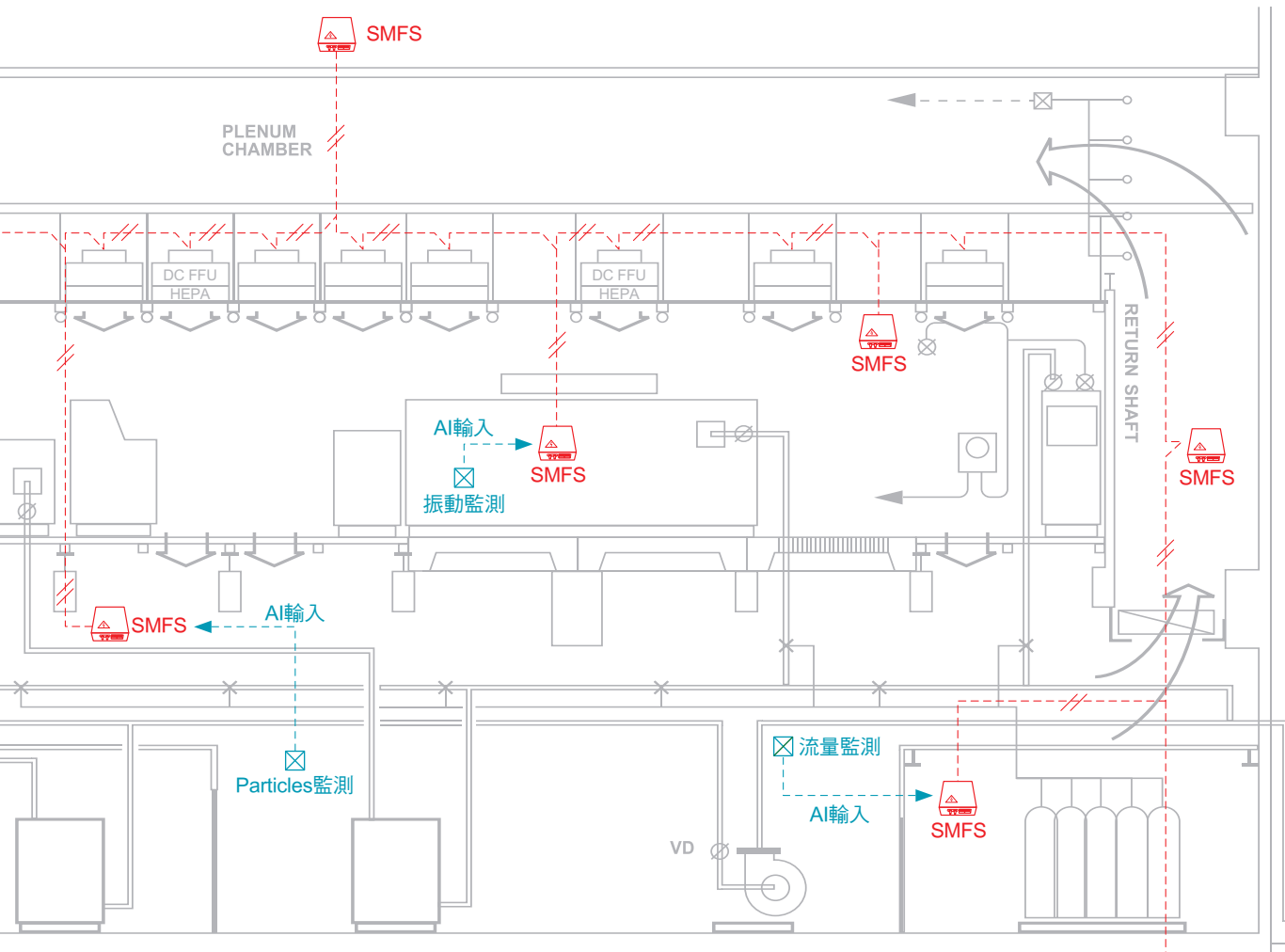

FFU 本體監控功能 FFU Body monitoring function

- ◆ 轉速、風量、濾網壓損、電力能耗、單控、群控、框選、單選、縮放...等。



系統說明請掃此QR-Code

自動化及製程設備專用FFU FFU for Automation/Process Equipment

相較於一般潔淨室環境需求，自動化及製程設備其潔淨環境有其特別要求，首要考量的是自動化設備移動時會產生的大量發塵如何加以抑制及排除，再者就是如何防止其周圍較低潔淨等級環境的污染(室壓的建立)。除潔淨環境外，自動化及製程設備所安裝的FFU還特別要求安裝高度(薄型化)。尤其是倉儲自動化的FFU，會需求側面安裝並固定於棚架，故在安裝方式需特別考量強度及維修時拆裝方便性。

Comparing to general cleanroom environment, the requirements of clean environment for automation/process equipment is even more critical. In consideration of massive amount of particle generation from moving of automation equipment, the suppression and exhaustion of contaminant shall be implemented in the cleanroom FFU design. Additionally, the room pressure shall be built up to prevent the surrounding contaminant from entering.

Besides of clean environment for automation/process, the minimum space is also required for the FFU selection. Especially when applied for Stocker installation, the characteristics of durability and easy maintenance shall be incorporated into the FFU design,

AMHS FFU Characteristics

Ball Room Circulation:

High Static Pressure
(~180-240Pa/fiber glass, ~130-170Pa/PTFE)

- ◆ Ceiling Mounted Type
Air Velocity(0.4m/s-0.6m/s)
- ◆ Side Mounted Type
Air Velocity(~0.3m/s), Thin Type, Installation consideration

Local Circulation:

Low Static Pressure
(~120Pa/fiber glass, 70Pa/PTFE)

- ◆ Side Mounted Type
Air Velocity(~0.3m/s), Thin Type, Installation consideration

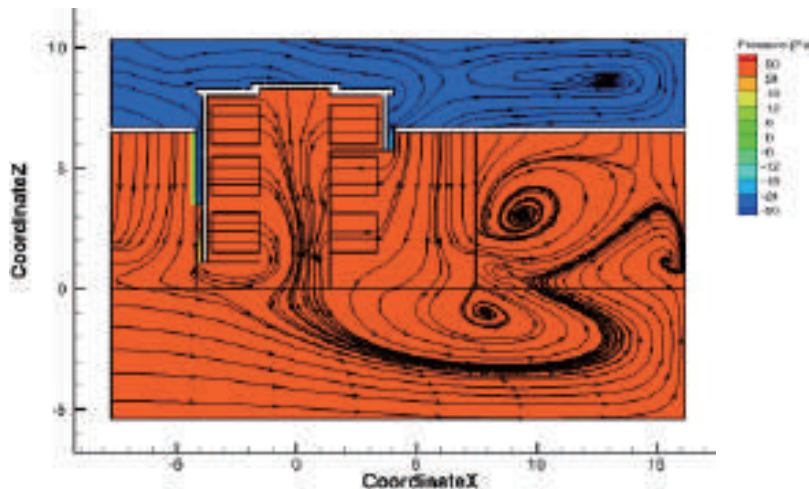
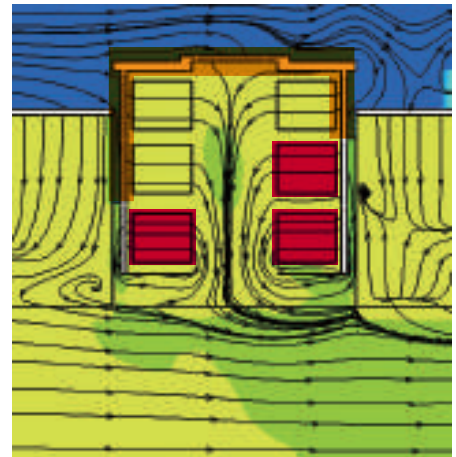

Stocker System-A

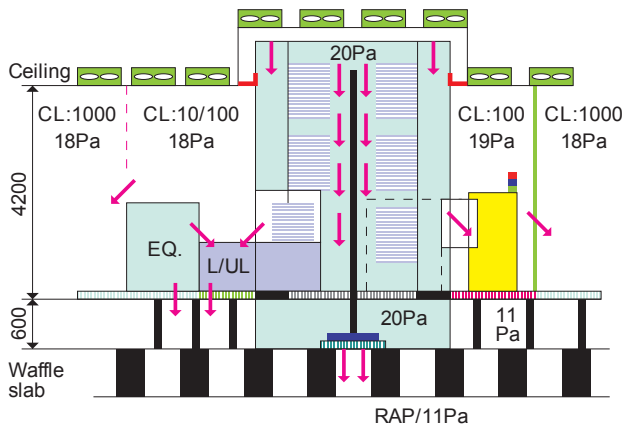

Stocker System-B

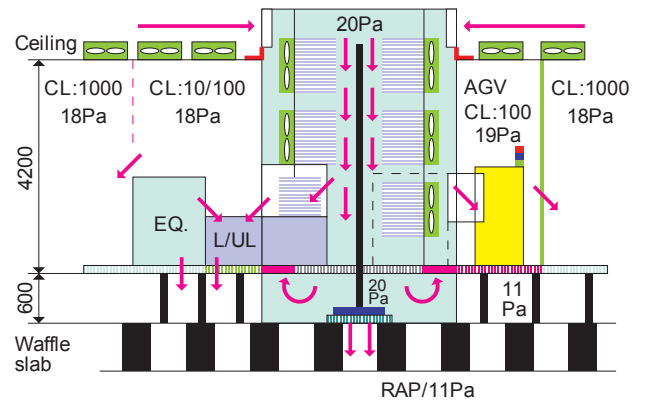

◆ STK壓力分佈圖-A

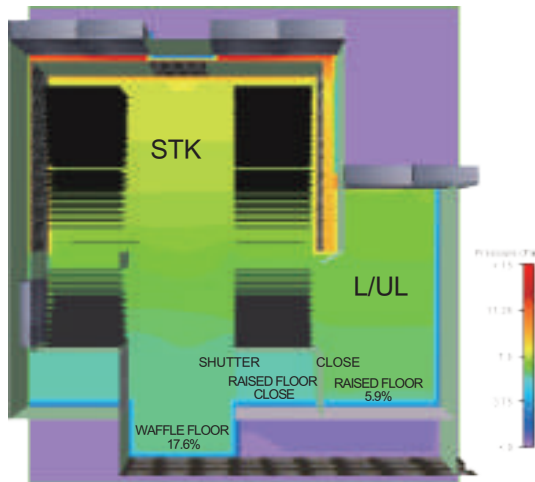

◆ STK壓力分佈圖-B

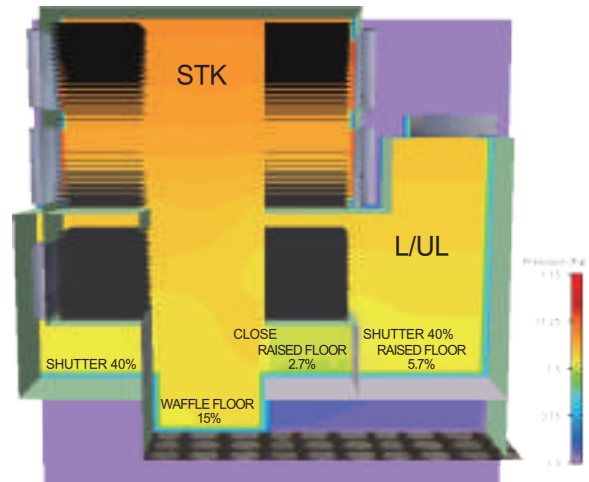

◆ STK氣流分佈圖-A

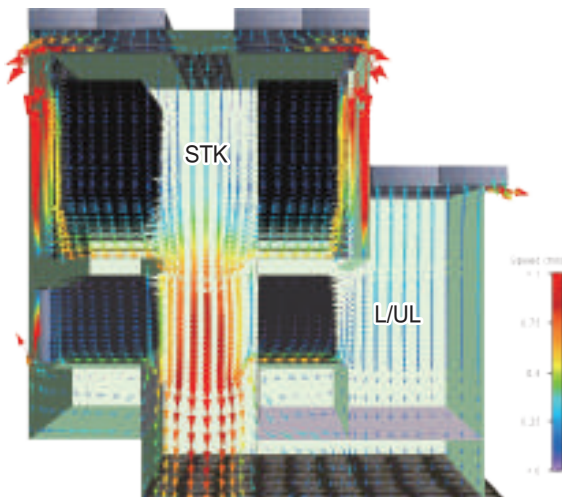

◆ STK氣流分佈圖-B

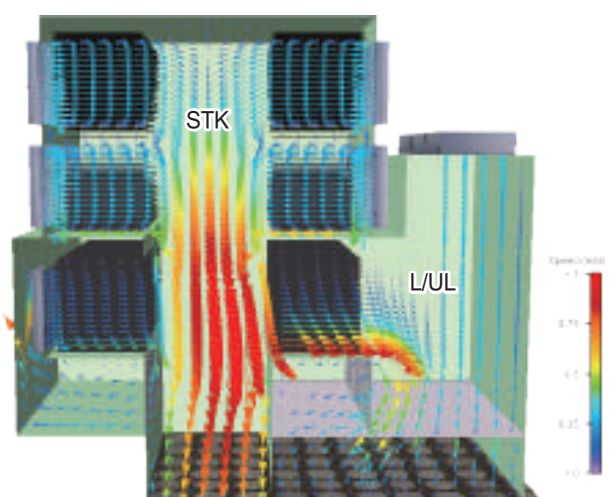

自動化及製程設備專用FFU FFU for automation and process equipment

外型尺寸及規格 Dimensions and specifications

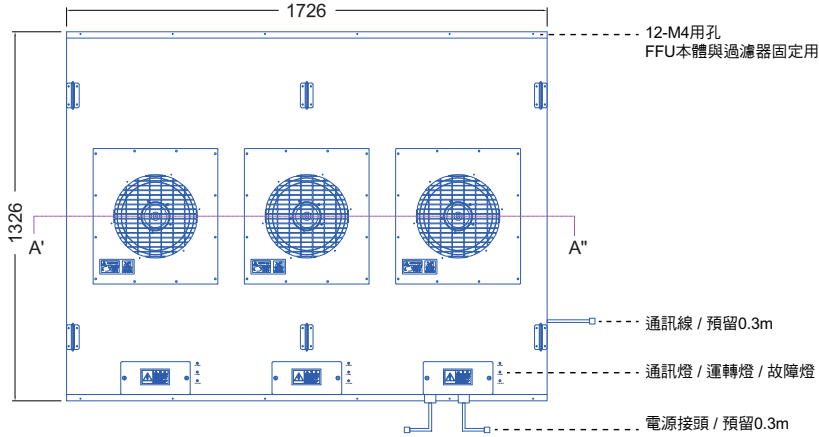

Specification	
Size	1726 x 1326 x 150 H
Working No	*****
Model	RR-1D2X2L1-04
Air Vol	35 CMM
Efficiency	0.3 μ m \geq 99.97%
Power	1 ϕ 200-220V \pm 10%
Freq	50/60 HZ
Consump	250 W
S/N	*****
Date	2016/**

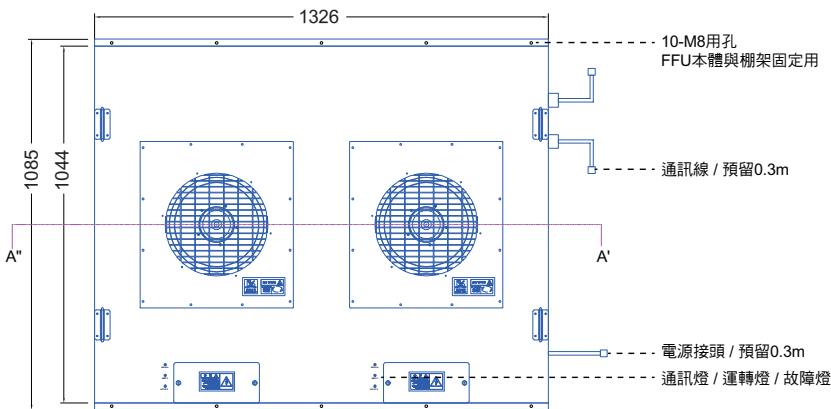

Specification	
Size	1044 x 1326 x 150 H
Working No	*****
Model	RR-1D2X2L1-02
Air Vol	21 CMM
Efficiency	0.3 μ m \geq 99.97%
Power	1 ϕ 200-220V \pm 10%
Freq	50/60 HZ
Consump	140 W
S/N	*****
Date	2016/**

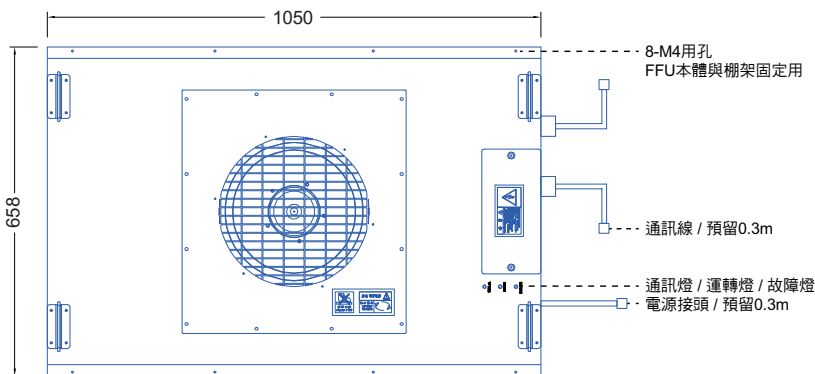

Specification	
Size	1050 x 658 x 150 H
Working No	*****
Model	RR-1D2X2L1-05
Air Vol	12 CMM
Efficiency	0.3 μ m \geq 99.97%
Power	1 ϕ 200-220V \pm 10%
Freq	50/60 HZ
Consump	76 W
S/N	*****
Date	2016/**

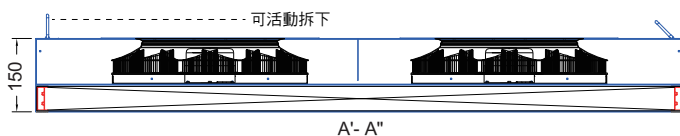

規格	高度 H mm	Max.OP(TSP=200Pa) Q. CMM	Power Input VA
薄型	200	10 ~ 39	160 ~ 330
超薄型	100	10 ~ 19	160

自動化及製程設備專用FFU
FFU for automation and process equipment

FFU及過濾器與棚架固定安裝方式 FFU and filter and scaffolding fixed installation

◆ 固定工法-A

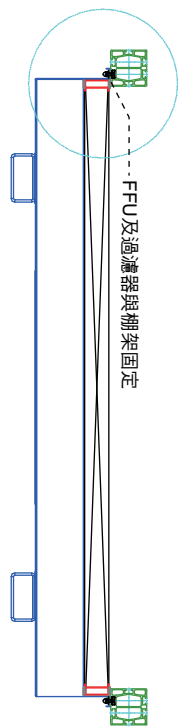

◆ 固定工法-B

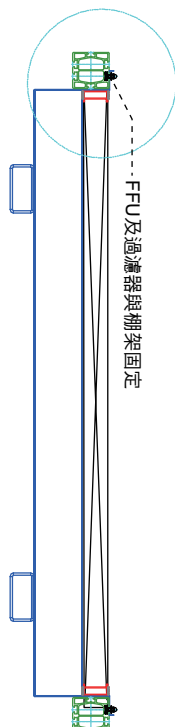

◆ 固定工法-A / 棚架固定

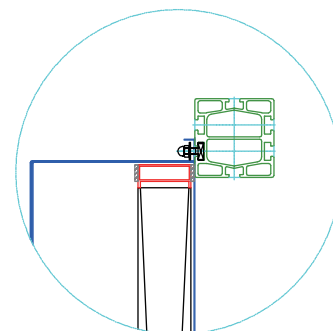

◆ 固定工法-B / 棚架固定

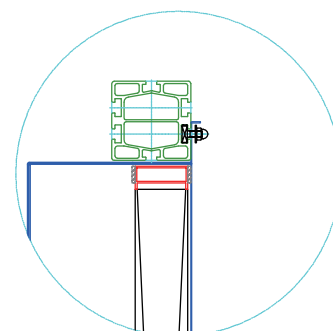

◆ 固定工法-C

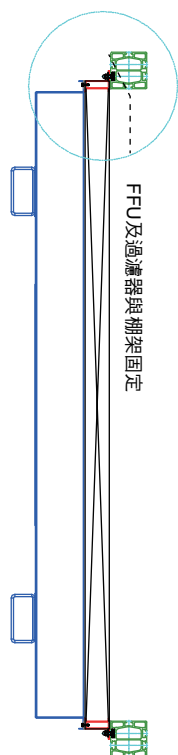

◆ 固定工法-D

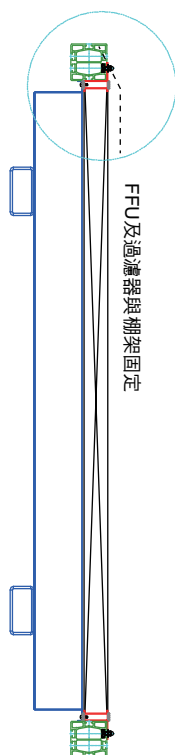

◆ 固定工法-C / 棚架固定

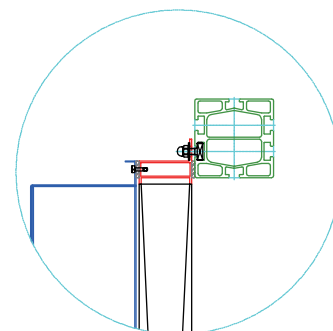

◆ 固定工法-D / 棚架固定

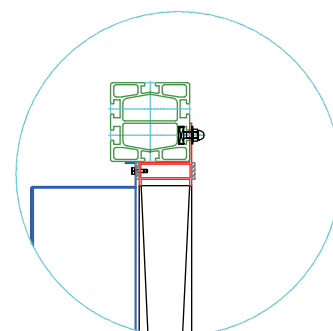

DC FFU 規格 DC FFU specifications

外型尺寸及規格 Dimensions and specifications

2x4 標準型	
外觀尺寸	1172x572x265
電源	1Ø-220/277V-50/60Hz
最大使用功率	150W
運轉能力	15-19CMM@TSP250Pa
最高整機效率	>51%
諧波(THDi)	<5%
電機	SF-305I100-T***
絕緣等級	E
防水防塵等級	IP30
馬達輸出	90W-150W
風扇	Ø305 (鋁合金)
箱體	鍍鋁鋅板
把手	SUS-304
重量	23 Kg

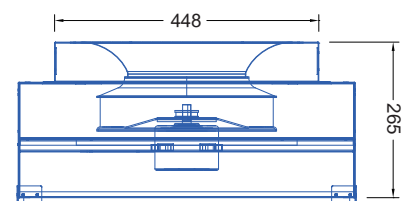
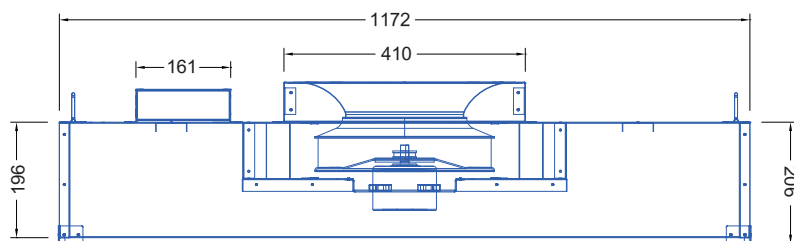
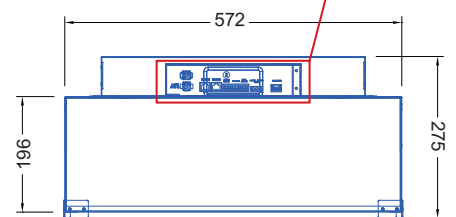
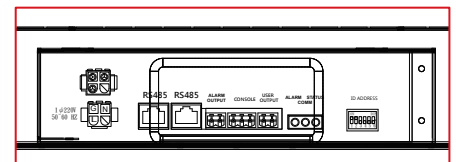
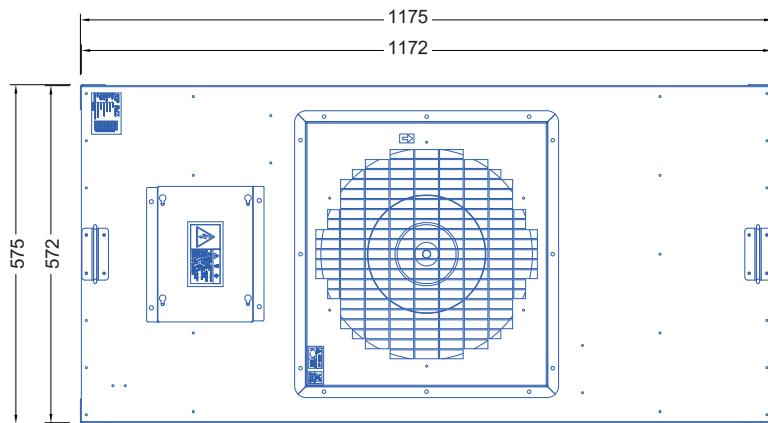
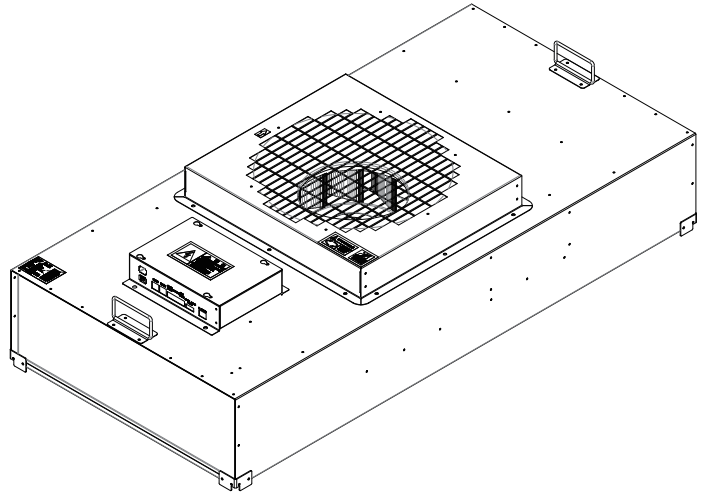

外型尺寸及規格 Dimensions and specifications

2x4 高效型	
外觀尺寸	1172x572x327
電源	1Ø-220/277V-50/60Hz
最大使用功率	200W
運轉能力	19-22CMM@TSP270Pa
最高整機效率	>54%
諧波(THDi)	<5%
電機	SF-390I120-T***
絕緣等級	E
防水防塵等級	IP30
馬達輸出	100W-250W
風扇	Ø390 (鋁合金)
箱體	鍍鋅板
把手	SUS-304
重量	26 Kg

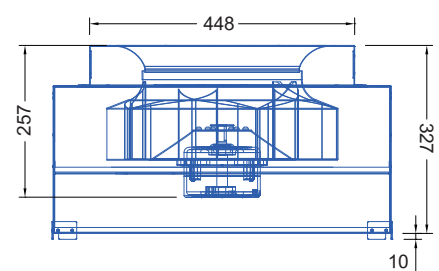
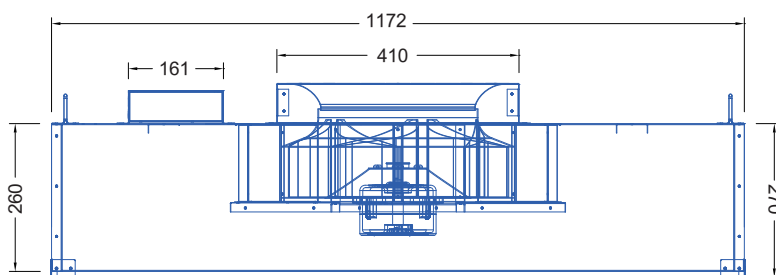
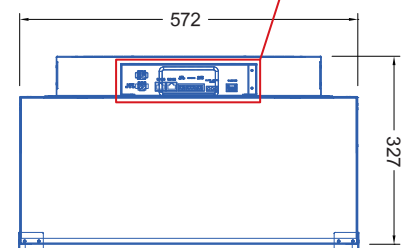
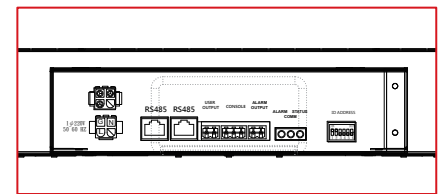
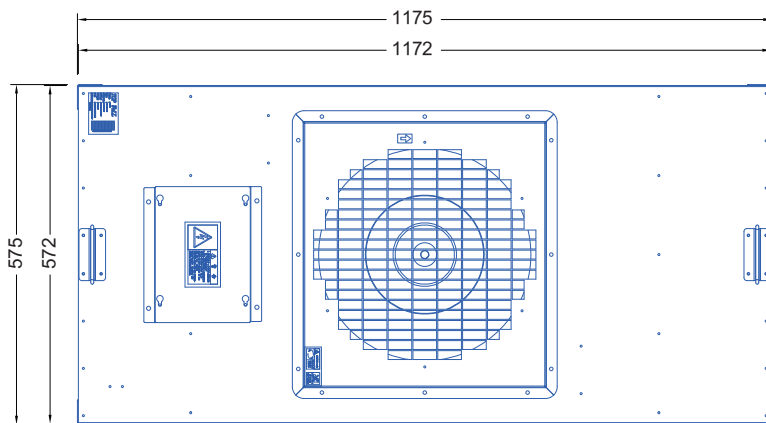
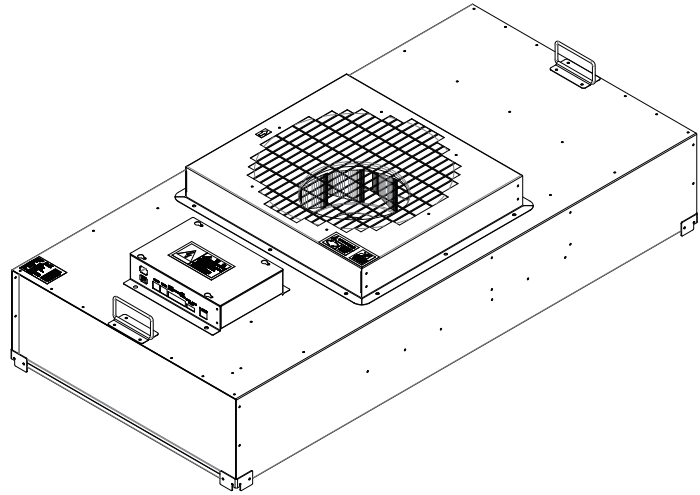

外型尺寸及規格 Dimensions and specifications

2x4 薄型	
外觀尺寸	1172x572x200
電源	1Ø-220/277V-50/60Hz
最大使用功率	150W
運轉能力	15-19CMM@TSP250Pa
最高整機效率	>52%
諧波(THDi)	<5%
電機	SF-305S084-T***
絕緣等級	E
防水防塵等級	IP54
馬達輸出	100W-250W
風扇	Ø305 (鋁合金)
箱體	鍍鋁鋅板
把手	SUS-304
重量	19 Kg

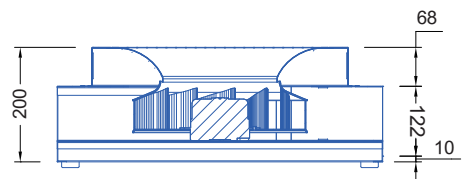
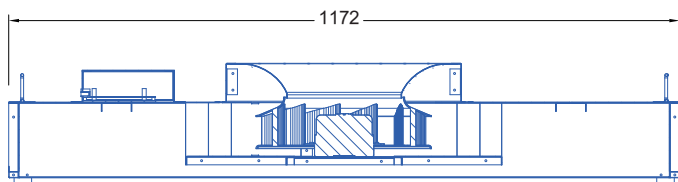
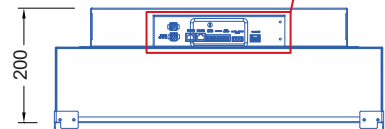
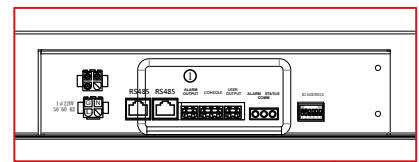
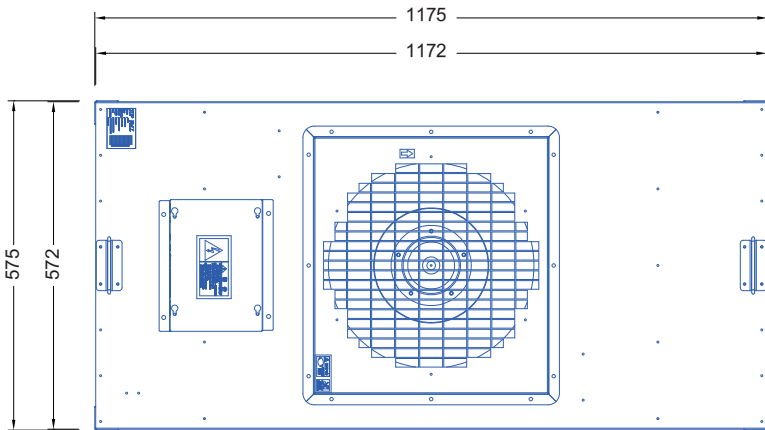
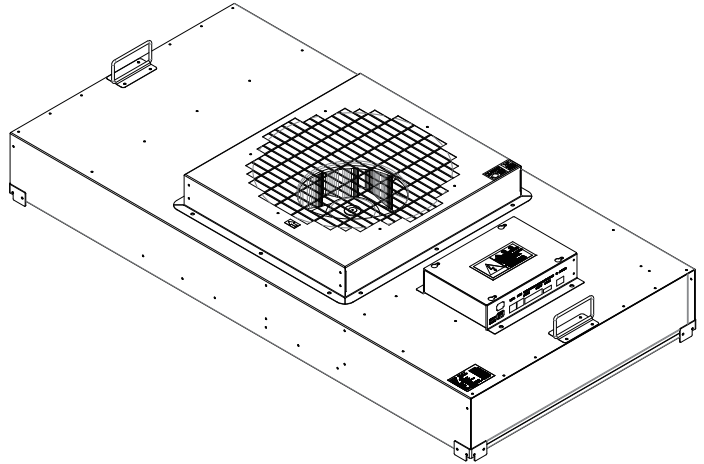

外型尺寸及規格 Dimensions and specifications

2x4 超薄型	
外觀尺寸	1172x572x100
電源	1Ø-220/277V-50/60Hz
最大使用功率	150W
運轉能力	14-18CMM@TSP200Pa
最高整機效率	>40%
諧波(THDi)	<10%
電機	SF-430S084-T***
絕緣等級	E
防水防塵等級	IP54
馬達輸出	100W-250W
風扇	Ø430 (鋁合金)
箱體	鍍鋅鋅板
把手	SUS-304
重量	13 Kg

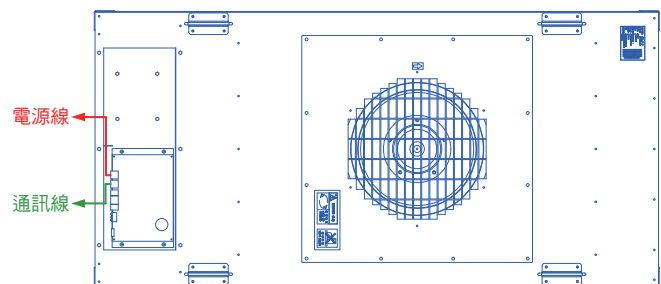
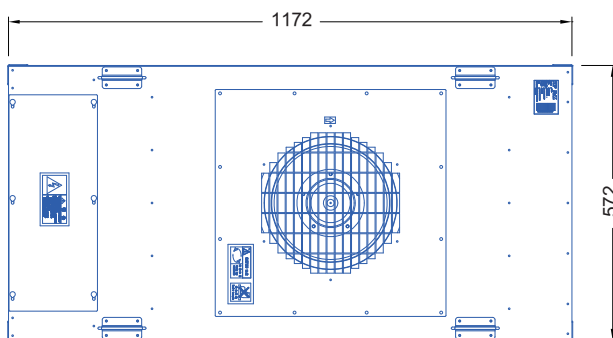
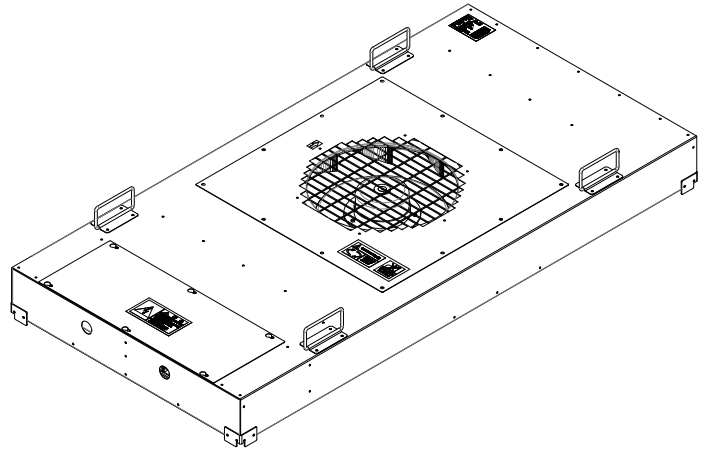

控制盒內部配置圖

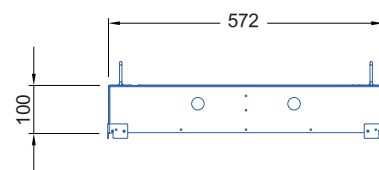
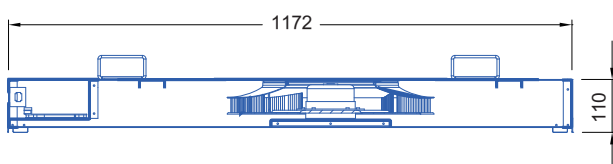

外型尺寸及規格 Dimensions and specifications

4x4 標準型	
外觀尺寸	1172x1172x380
電源	1Ø-220/277V-50/60Hz
最大使用功率	375W
運轉能力	30-39CMM@TSP270Pa
最高整機效率	>58%
諧波(THDi)	<5%
電機	SF-458S101-T***
絕緣等級	E
防水防塵等級	IP54
馬達輸出	90W-350W
風扇	Ø448 (鍍鋁鋅)
箱體	鍍鋁鋅板
把手	SUS-304
重量	52 Kg

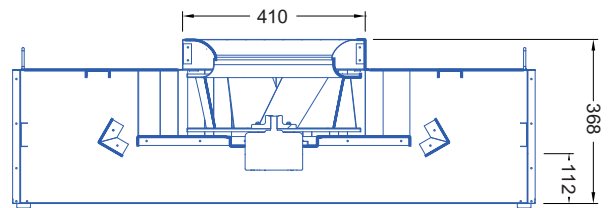
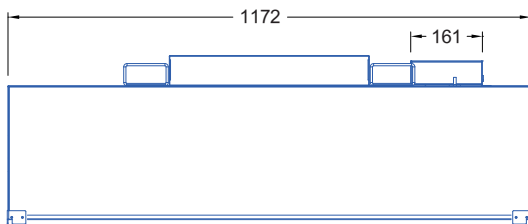
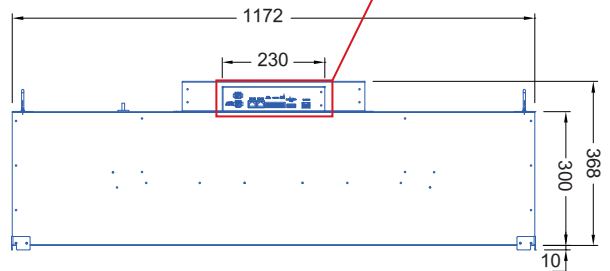
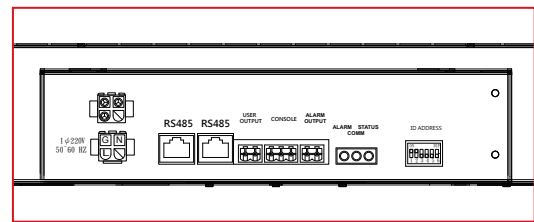
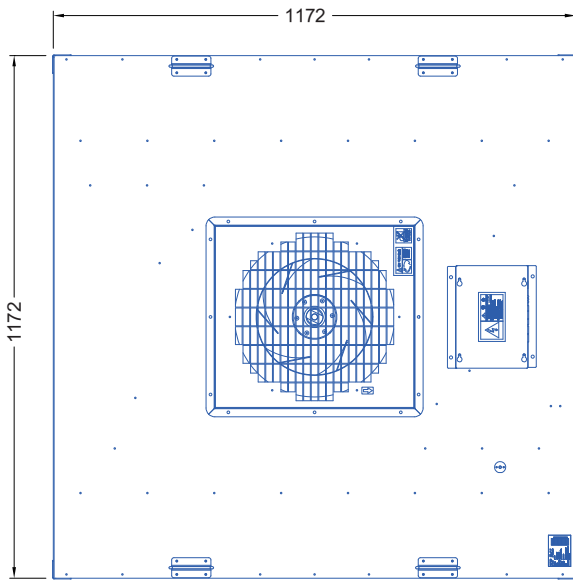
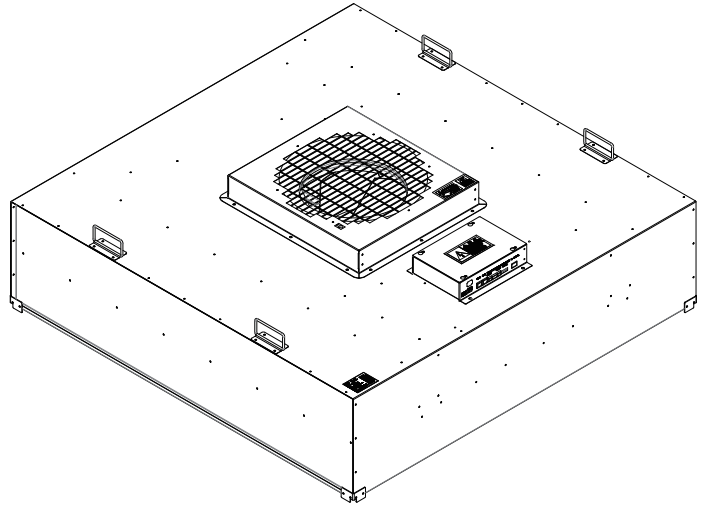

外型尺寸及規格 Dimensions and specifications

4x4 高效型	
外觀尺寸	1172x1172x380
電源	1Ø-220/277V-50/60Hz
最大使用功率	500W
運轉能力	30-39CMM@TSP270Pa
最高整機效率	>62%
諧波(THDi)	<5%
電機	SF-458S101-T***
絕緣等級	E
防水防塵等級	IP54
馬達輸出	90W-350W
風扇	Ø448 (鍍鋁鋅)
箱體	鍍鋁鋅板
把手	SUS-304
重量	53 Kg

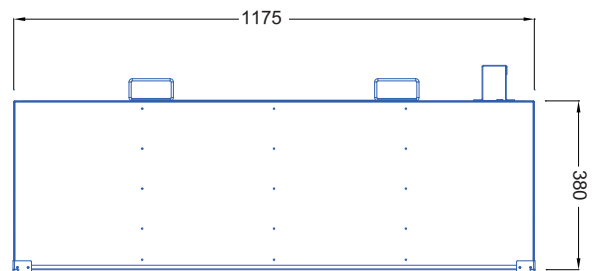
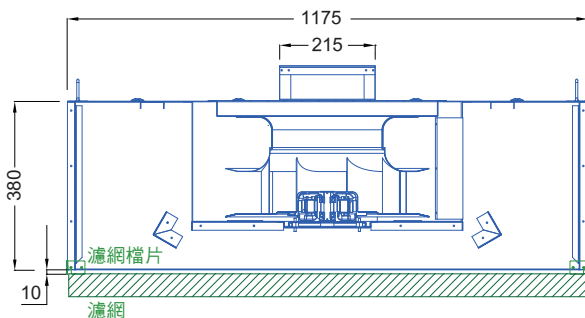
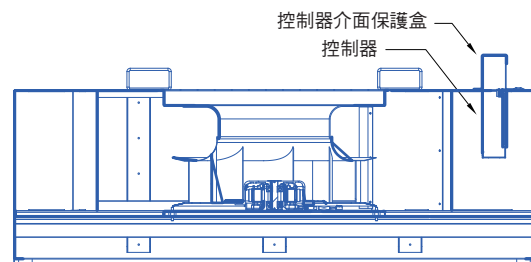
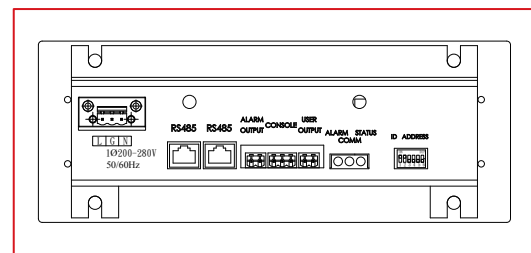
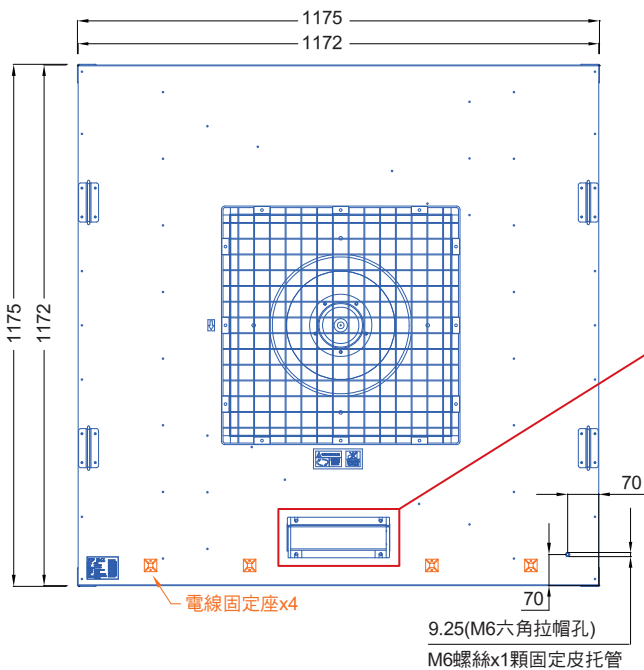
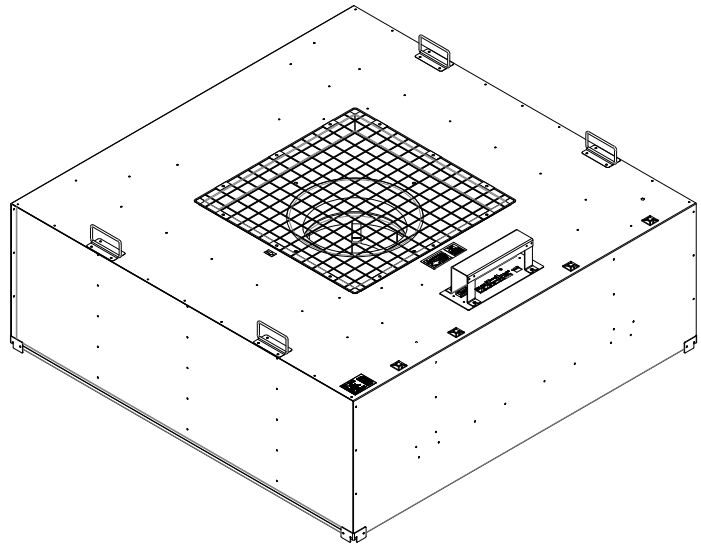

外型尺寸及規格 Dimensions and specifications

4x4 薄型	
外觀尺寸	1172x1172x200
電源	1Ø-220/277V-50/60Hz
最大使用功率	300W
運轉能力	30-37CMM@TSP220Pa
最高整機效率	>47%
諧波(THDi)	<5%
電機	SF-400S084-T***
絕緣等級	E
防水防塵等級	IP54
馬達輸出	90W-250W
風扇	Ø400 (鋁合金)
箱體	鍍鋅鋅板
把手	SUS-304
重量	30 Kg

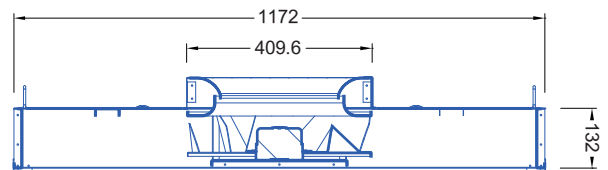
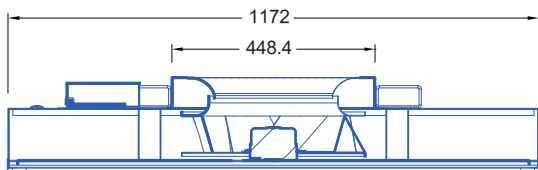
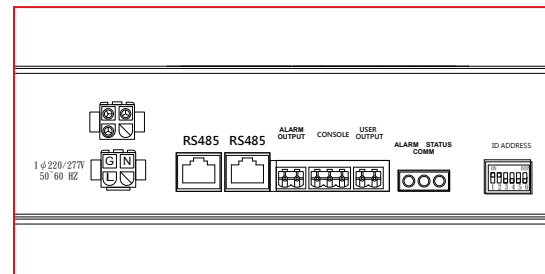
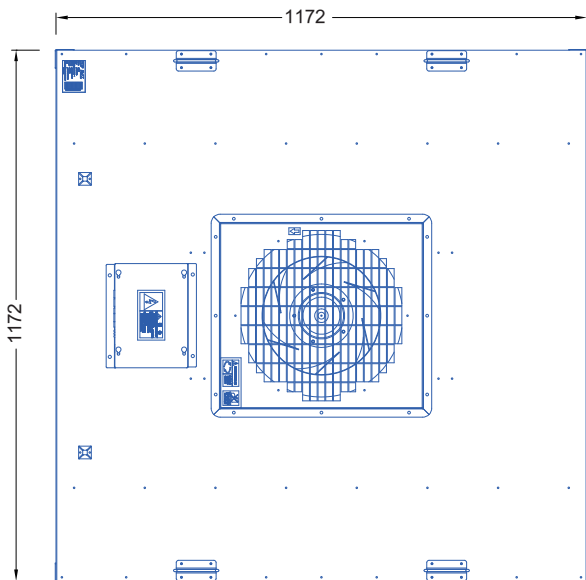
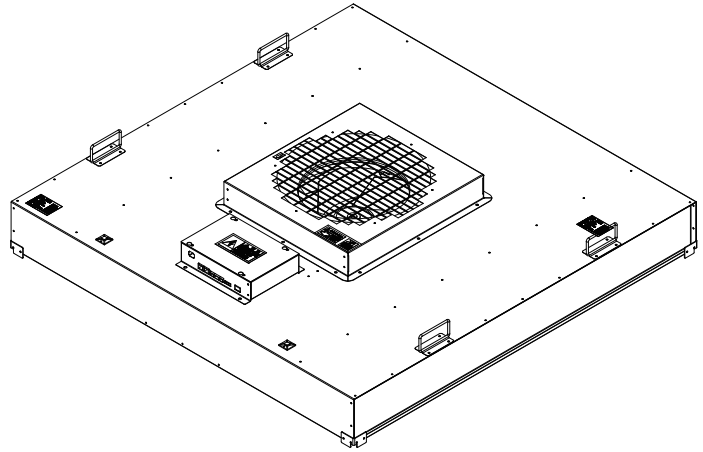

FFU馬達 | 基板 | 圖控系統 新舊更替、整合轉換工程



項目一

Service Items 1

AC馬達改換DC馬達 + 圖控系統工程。

項目二

Service Items 2

AC FFU無監控系統，改成有監控系統。

項目三

Service Items 3

原TOPRE、SINKO、FUJI、Gebhardt、M+W等品牌FFU，或採用EBM馬達的FFU，更新馬達或控制基板，並改設成開放式Intouch、Ifix圖控系統工程。



以上工作，topwell均已有完成整改的案例，
歡迎有相同需求的朋友，來電函諮詢交流。

www.topwell-pes.com



QR-CODE



📍 台灣公司：台南市新營區(工業區)五福路25號
 No.25, Wufu Rd., Xinying Dist., Tainan City 73054, Taiwan

奇立實業股份有限公司 CHYI LEE INDUSTRY CO., LTD.

(台北) TEL : 886-2-29069201 FAX : 886-2-29068821 | (江蘇) TEL : +86-512-57770491-2
 (台南) TEL : 886-6-6532185 FAX : 886-6-6532547 | FAX : +86-512-57754101

E-mail : pes@ms41.hinet.net

www.topwell-pes.com



📍 中國公司：江蘇省昆山市前進西路1888號時代中央花園
 17棟三單元306室

Room 306, Unit 3, Building 17, Times Central Garden, No.1888
 Qianjin West Road, Kunshan City, Jiangsu Province 215300