

模組式潔淨室 Modular Cleanroom



接水接電即可運轉
Immediate operation upon utilities hook-up

醫美診所

Aesthetic clinic

手術室

Surgery Room

Research Room
研究室

Work station

實驗室

Laboratory

工作室

TOPWELL



運用一 潔淨工作環境之區隔

特性:

1. 可於現有廠房中增設而不會干涉現有設施
2. 隔間系統為獨立結構可橫跨生產機具(跨距可達6公尺)
3. 可配合機台外型尺寸施作、佔地小、保持動線
4. 可拆裝重覆使用

適用場合:

在一般作業環境中，區隔一特定作業環境以防止周遭之作業污染，例如食品廠之產品充填包裝機區或隱形眼鏡其他業別之產品存放區。

適用業別:

食品、製藥、光電、半導體廠製程設備零件廠及一般電子業。

Application Case 1 Enclosure for controlled environment

Characteristics:

1. Capable of installation in existing production area
2. Independent structure allow to cross over equipment(up to 6 meters of span)
3. Customized design to minimize the space requirement
4. Easy to assemble and disassemble for relocating

Application:

Installation of an enclosure in general working environment, in order to define a controlled environment to prevent the pollution from the surrounding. For example, the filling/packing area for food processing manufacturer or the product storage for other manufacturer.

Industry:

Foods, pharmaceuticals, semiconductor manufacturing equipment/parts supplier and electronics .

軟簾式工作棚 Soft Wall Type Enclosure

單一工作棚 Single Enclosure

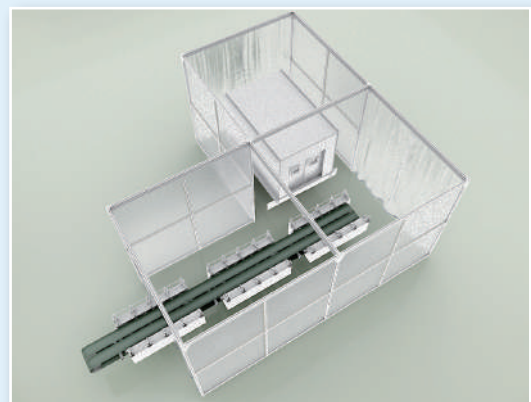

生產線工作棚 Production Live Enclosure

硬板式工作棚 Hard Wall Type Enclosure

單一工作棚 Single Enclosure

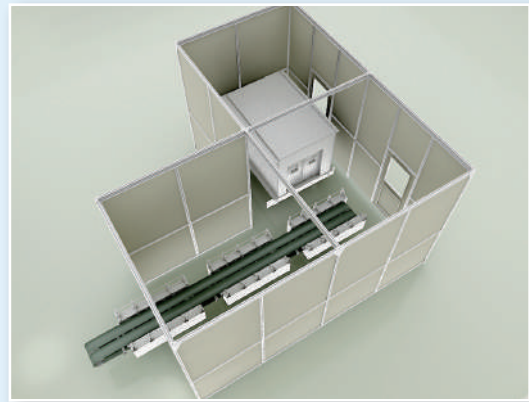

生產線工作棚 Production Live Enclosure

運用二 潔淨等級工作環境之建立

特性:

1. 可建立不同潔淨等級(Class 10-10,000)
2. 可於現有廠房中增設而不會干涉現有設施
3. 隔間系統為獨立結構可橫跨生產機具(跨距可達6公尺)
4. 可配合機台外型尺寸施作、佔地小、保持動線
5. 可拆裝重覆使用

適用場合:

在一般作業環境中，區隔一特定作業環境並建立潔淨等級，隔絕周遭之作業污染，例如食品、製藥或電子廠之產品包裝/組裝區或產品存放區。

適用業別:

食品、製藥、光電、半導體及精密電子業。

Application Case 2 Enclosure for clean room environment

Characteristics:

1. Capability of cleanness control
2. Capable of installation in existing production area
3. Independent structure allow to cross over equipment(up to 6 meters of span)
4. Customized design to minimize the space requirement
5. Easy to assemble and disassemble for relocating

Application:

Installation of an enclosure in general working environment, in order to establish a clean environment to create clean room and to prevent the pollution from the surrounding. For example, the packing/assembly or product storage area for food processing, pharmaceutical and microelectronic manufactures.

Industry:

Foods, pharmaceuticals and microelectronics .



軟簾式潔淨棚 Soft Wall Type Clean Booth

單一潔淨棚 Single Clean Booth



潔淨棚附設緩衝室 Clean Booth w/ Buffer Room

硬板式潔淨棚 Hard Wall Type Clean Booth

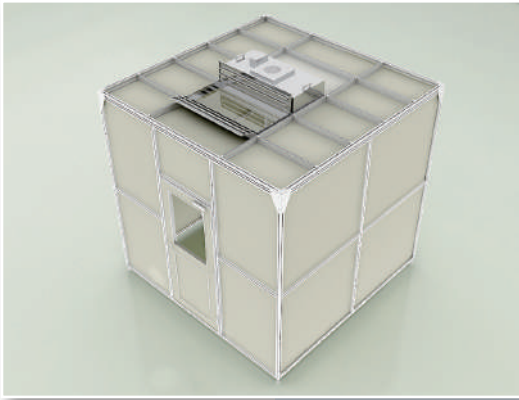

單一潔淨棚 Single Clean Booth

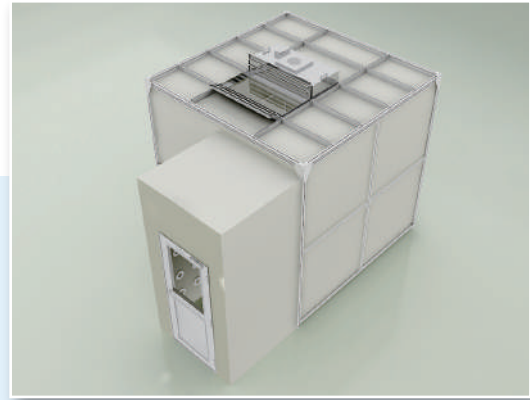

潔淨棚附設氣淋室 Clean Booth w/ Air Shower

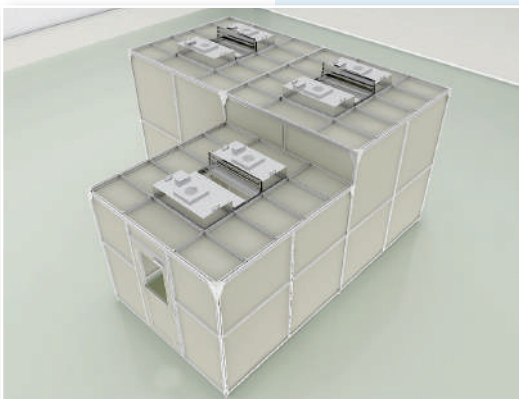

生產線潔淨棚 Production Line Clean Booth

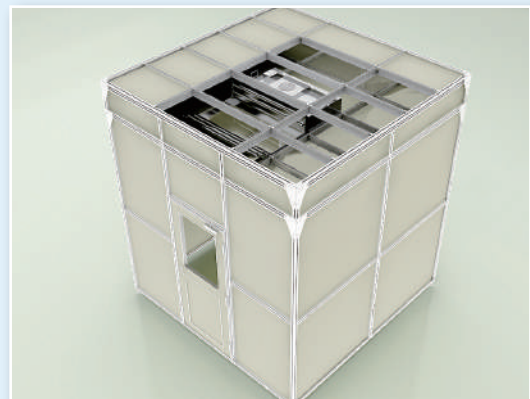

頂部回風內循環式 Chamber recirculated type

運用三 恆溫潔淨室之建立

特性:

1. 可建立不同潔淨等級(Class 10-10,000)及恆溫控制
2. 可於現有廠房中增設而不會干涉現有設施
3. 隔間系統為獨立結構可橫跨生產機具(跨距可達6公尺)
4. 可配合機台外型尺寸施作、佔地小、保持動線
5. 可拆裝重覆使用

適用場合:

在一般作業環境中，區隔一特定作業環境並建立潔淨等級及恆溫控制，隔絕周遭之作業污染以確保產品良率，例如生化製藥或電子廠之特殊產品生產區。

適用業別:

生化製藥業及精密電子業。

Application Case 3 Clean Booth with temperature control

Characteristics:

- 1.Capability of cleanness and temperature control
- 2.Capable of installation in existing production area
- 3.Independent structure allow to cross over equipment(up to 6 meters of span)
- 4.Customized design to minimize the space requirement
- 5.Easy to assemble and disassemble for relocating

Application:

Installation of an enclosure in general working environment, in order to establish a clean room with controlled temperature and to prevent the pollution from the surrounding. For example, the packing/assembly or product storage area for food processing, pharmaceutical and microelectronic manufactures.

Industry:

Foods, pharmaceuticals and microelectronics.

恆溫潔淨室 Clean Booth for temperature controlled and clean room environment

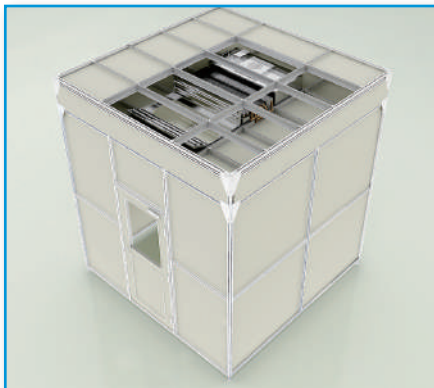

頂部回風內循環式 Chamber recirculated type

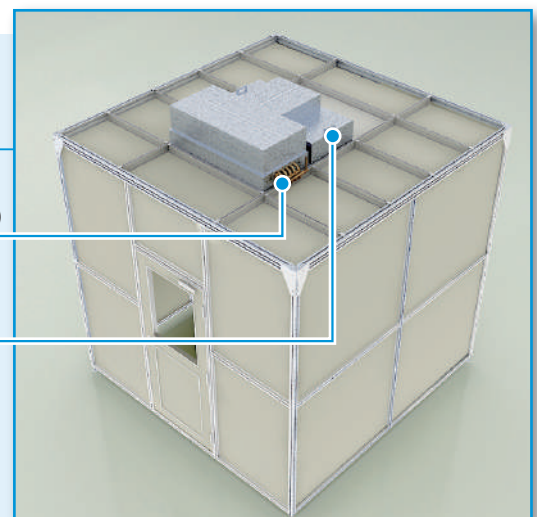

冷卻盤管 (Cooling Coil)

濾網風車組 (FFU)

風管回風 Duct recirculated type



運用四

恆溫恆濕潔淨室之建立

特性:

1. 可建立不同潔淨等級及恆溫恆濕控制
2. 可於現有廠房中增設而不會干涉現有設施
3. 隔間系統為獨立結構可橫跨生產機具(跨距可達6公尺)
4. 可配合機台外型尺寸施作、佔地小、保持動線
5. 可拆裝重覆使用

適用場合:

在一般作業環境中，區隔一特定作業環境並建立潔淨等級及恆溫恆濕控制，隔絕周遭之作業污染以確保產品良率，例如生化或半導體電子廠之特殊產品生產區。

適用業別:

生化製藥業及半導體電子業。

Application Case 4

Clean room with precise temperature/humidity control

Characteristics:

1. Capability of cleanness and constant control on temperature and humidity
2. Capable of installation in existing production area
3. Independent structure allow to cross over equipment(up to 6 meters of span)
4. Customized design to minimize the space requirement
5. Easy to assemble and disassemble for relocating

Application:

Installation of an enclosure in general working environment, in order to establish a clean room with controlled precise temperature and humidity, and to prevent the impact from the surrounding. For example, the critical production area for bio-tech and microelectronic manufacturers.

Industry:

Bio-tech and semiconductor microelectronics.

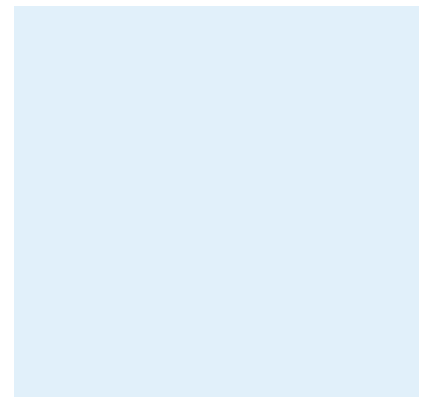

恆溫潔淨室

Clean Booth for temperature controlled and clean room environment

恆溫恆濕潔淨室

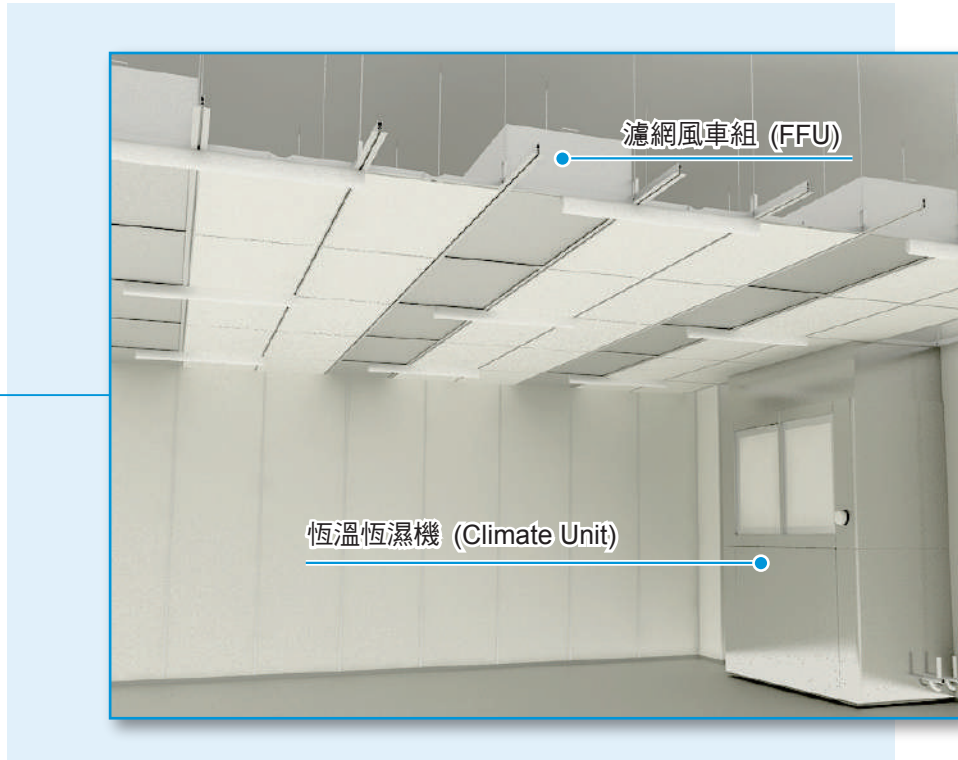

恆溫恆濕潔淨室廠區

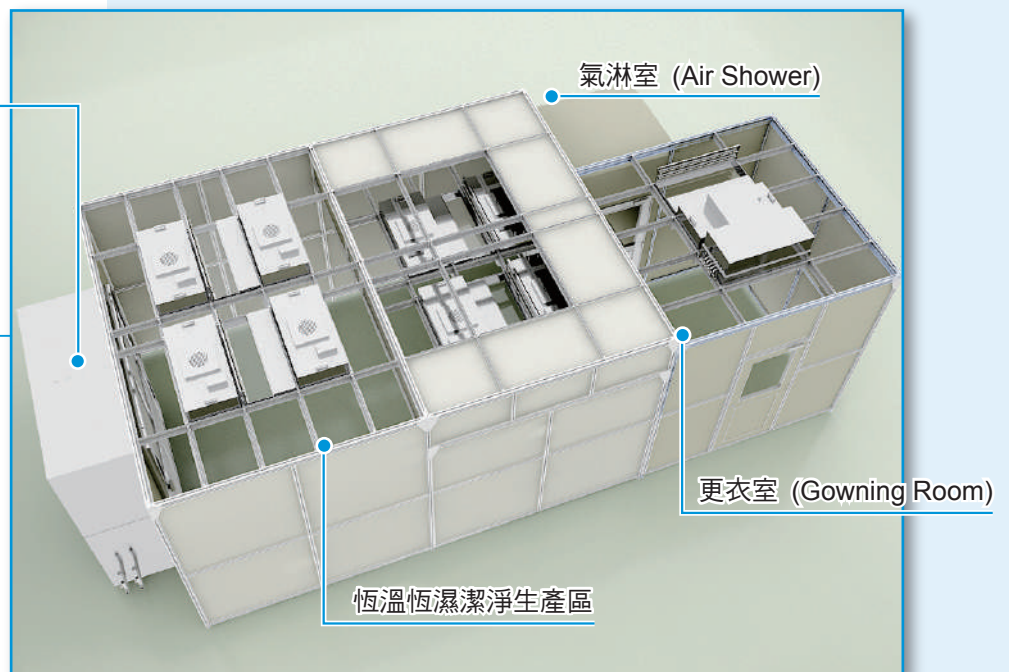



產品行銷中、日、台等國。
Selling products in China , Japan and Taiwan.

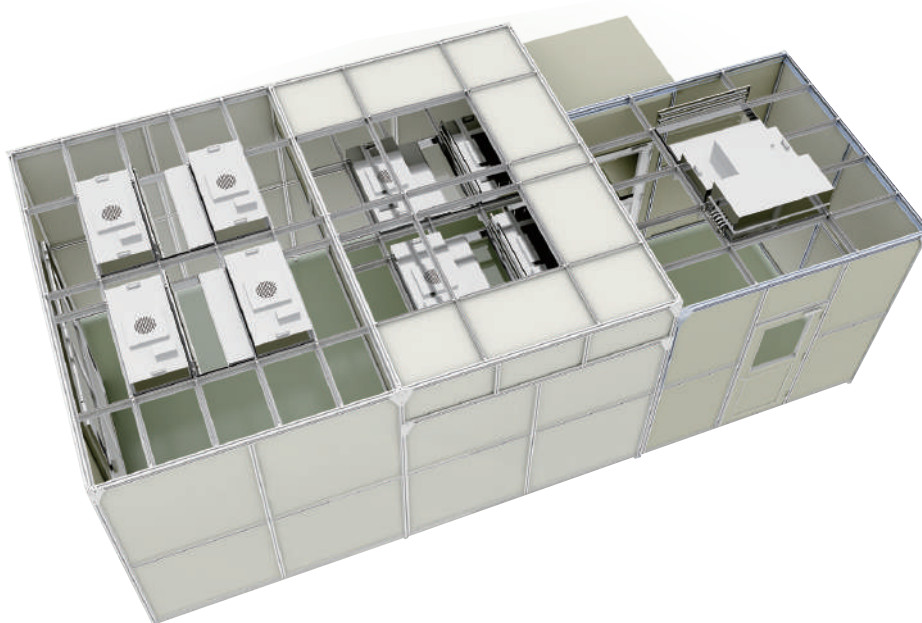

奇立實業股份有限公司 CHYI LEE INDUSTRY CO., LTD.

台南市新營區(工業區)五福路 25 號
(台北) TEL: 886-2-29069201 FAX: 886-2-29068821
(台南) TEL: 886-6-6532185 FAX: 886-6-6532547
No. 25, Wufu Rd., Xinying Dist., Tainan
City 73054, Taiwan

江蘇省昆山市前進西路1888號時代中央花園17棟306室
TEL: +86-512-57770493 FAX: +86-512-57754101
Room 306, No. 17 Building, Times Central Garden, No. 1888
Qianjin West Road, Kunshan City, Jiangsu Province 215300

<http://www.Topwell-pes.com>

E-mail: pes@ms41.hinet.net